



OPERATING INSTRUCTIONS

PMR446 TRANSCEIVER

IC-F29SR



Icom Inc.

INTRODUCTION

FOREWORD

Thank you for purchasing this Icom transceiver.

IMPORTANT

FIRST, CAREFULLY READ INSTRUCTIONS

that are provided with the transceiver.

SAVE THIS OPERATING INSTRUCTIONS—

These operating instructions contain additional important operating instructions for the IC-F29SR PMR446 TRANSCEIVER.

TABLE OF CONTENTS

FOREWORD	i
IMPORTANT	i
TABLE OF CONTENTS	i
1 ACCESSORIES	1-2
Accessory attachments	1
◇ Battery pack	1
◇ Belt clip	1
◇ Jack cover	2
2 PROGRAMMABLE KEY FUNCTIONS.....	3
Programmable key functions	3
3 LED INDICATOR.....	4
About the LED indicator	4
4 SETTINGS	5-11
Setting the Beep function	5
Setting the beep level.....	6
Setting the ringer level.....	7
Setting the group code number	8
◇ CTCSS tone setting.....	8
◇ DTCS code setting	9
Setting the microphone gain	10
Setting the squelch level	11

Icom, Icom Inc. and the Icom logo are registered trademarks of Icom Incorporated (Japan) in Japan, the United States, the United Kingdom, Germany, France, Spain, Russia and/or other countries.

All other products or brands are registered trademarks or trademarks of their respective holders.

Section 1 ACCESSORIES

Accessory attachments

◇ Battery pack

Attach or remove the battery pack, as illustrated to the right.

To attach the battery pack:

- ① Place the tabs on the bottom of the battery pack into the slots at the bottom of the transceiver. (1)
- ② Push the battery pack until the battery release buttons make a 'click' sound. (2)

To remove the battery pack:

- ① Push the battery release buttons in the direction of the arrow as shown to the right. (3)
- ② The battery pack is then released, and you can remove it. (4)

To attach

Battery release buttons

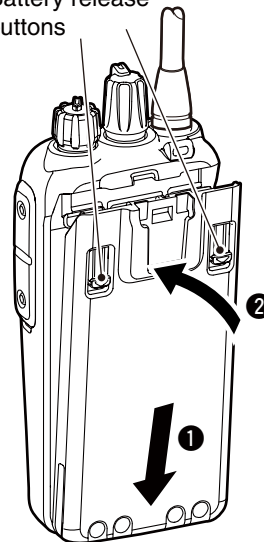

To remove

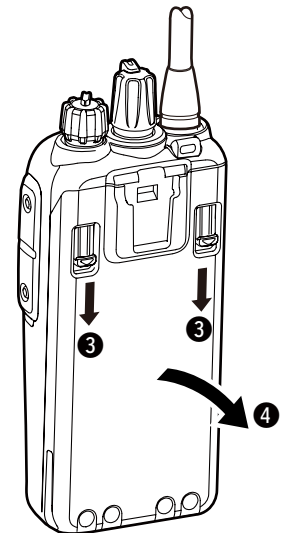

◇ Belt clip

NOTE: Before attaching or detaching the belt clip, remove the battery pack from the transceiver, if it is attached.

To attach the belt clip:

- ➔ Slide the belt clip in the direction of the arrow until the belt clip locks in place, and makes a 'click' sound. (1)

To detach the belt clip:

- ➔ Lift the tab up (2), and slide the belt clip in the direction of the arrow (3).

To attach

To detach

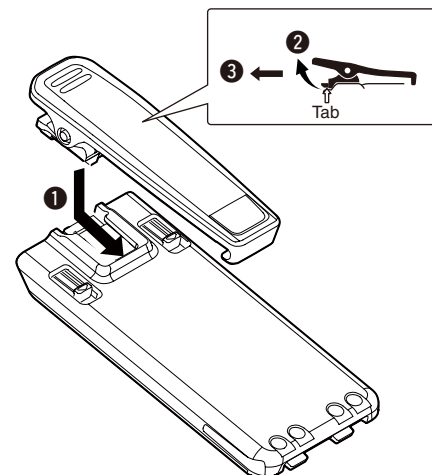

Accessory attachments (Continued)

◇ **Jack cover**

/// **CAUTION:** The transceiver meets IP67 requirements for dust-tight and waterproof protection, only when the jack cover or the optional HM-168LWP SPEAKER MICROPHONE is attached.

To attach the jack cover:

- ① Place the jack cover over the speaker-microphone jack. (1)
- ② Insert and tighten the screws. (2)

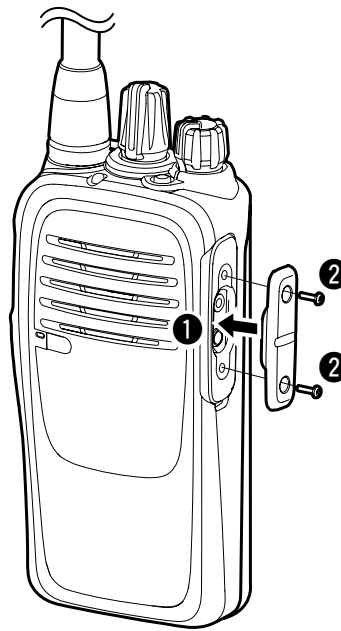

To detach the jack cover:

- ① Unscrew the screws using a Phillips screwdriver. (3)
- ② Detach the jack cover. (4)

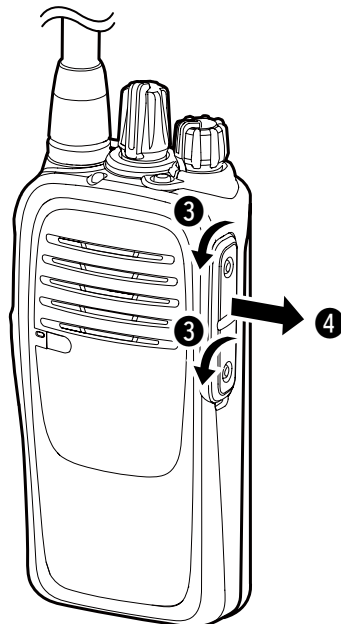

Programmable key functions

If you use the CS-F29SR CLONING SOFTWARE (purchase separately), you can assign the functions described below to [TOP], [Upper], and [Lower].

/// **NOTE:** Refer to the instruction sheet that comes with the transceiver for the default settings of these keys.

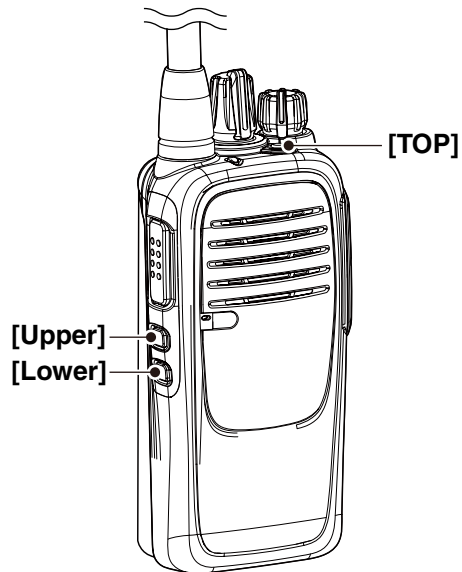

SCAN START/STOP

- Push to start and cancel a scan.
 - When a scan is started with the Power ON Scan or Automatic scan function, push this key to pause it. The paused scan resumes after a set time period.

PRIORITY A CHANNEL, PRIORITY B CHANNEL

- Push to select the Priority A or Priority B channel.

PRIORITY A CHANNEL (REWRITE), PRIORITY B CHANNEL (REWRITE)

- Push to select the Priority A or Priority B channel.
- Hold down to set the operating channel as the Priority A or Priority B channel.

MEMORY CHANNELS 1, 2, 3, 4

- Push to select memory channel 1, 2, 3, or 4.

MONI

- Push to turn the CTCSS (DTCS) mute ON or OFF.
- While holding down this key, the transceiver opens any squelch, or releases any mute.

LOCK

- Hold down to turn the Key Lock function ON or OFF.
 - Even when the Lock function is ON, [MONI] and [SURVEILLANCE] are not locked.

SURVEILLANCE

- Hold down to turn ON the Surveillance function.
- Push to turn OFF the function.
 - When this function is ON and a signal is received, a beep does not sound and the status indicator does not light, even if you push any key.

SIREN

- Hold down to emit a siren sound.
 - The transceiver keeps emitting the siren sound until the transceiver's power is turned OFF.
 - This function is for situations other than an emergency alert, such as a security alarm.

SCRAMBLER

- Hold down to turn ON the Voice Scrambler function.
- Push to turn OFF the function.

COMPANDER

- Hold down to turn ON the Compander function.
- Push to turn OFF the function.
 - The Compander function reduces noise components from the transmitted audio to provide clear communication.

S-RING/C-RING

- Push to make a Smart-Ring call.
- Hold down to make a Call-Ring call.

ANNOUNCE

- Push to turn the Channel Announce function ON or OFF.
 - The transceiver announces the position of [Rotary Selector].

/// **NOTE:** When the Beep function is OFF, the operating channel is not announced, regardless of this setting. (p. 5)

Section 3 LED INDICATOR

About the LED indicator

The LED indicator indicates the status of various parameters of the transceiver as follows:
 (Reference: R is Red, G is Green, O is Orange)

- Cloning (reading or writing data)

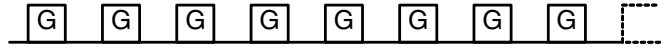

- Cloning error (if cloning fails)



- Inh, Blank CH, Unlocked (when you cannot use the channel)



- TX Low Battery 1 (while transmitting)



- TX Low Battery 2 (while transmitting)



- Transmitting



- Receiving

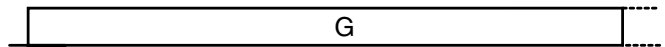

- Scanning

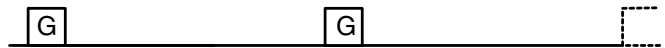

- Low Battery 1 (You should charge the battery.)



- Low Battery 2 (You must charge the battery.)

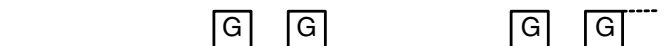

- When turning ON the power



- Making a Smart-Ring call



- Lockout, TX Inh, TOT (when transmit is inhibited)



- Smart-Ring call successful



- Smart-Ring call failed



- Siren

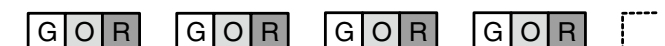

Setting the Beep function

The Beep function can be turned ON or OFF. When it is OFF, the channel announcement is also turned OFF.

NOTE: You should turn ON the Beep function when you set the microphone gain, the squelch level or the group code number to check the current level setting with the beep sounding. (pp. 8–11)

- ① Rotate **[VOL]** to turn OFF the transceiver power.
- ② Set **[ROTARY SELECTOR]** to any channel other than Channel 16.
- ③ While holding down **[Lower]**, rotate **[VOL]** to turn ON the power to enter the Beep level adjustment mode.
- ④ Push **[Lower]** to turn the Beep function ON or OFF.
 - When a beep sounds after pushing **[Lower]**, the Beep function is ON. When no beep sounds after pushing **[Lower]**, the Beep function is OFF.
 - If desired, push **[Upper]** to adjust the Beep level. See page 6 for details.
- ⑤ Rotate **[VOL]** to turn OFF the power to exit the Beep level adjustment mode.

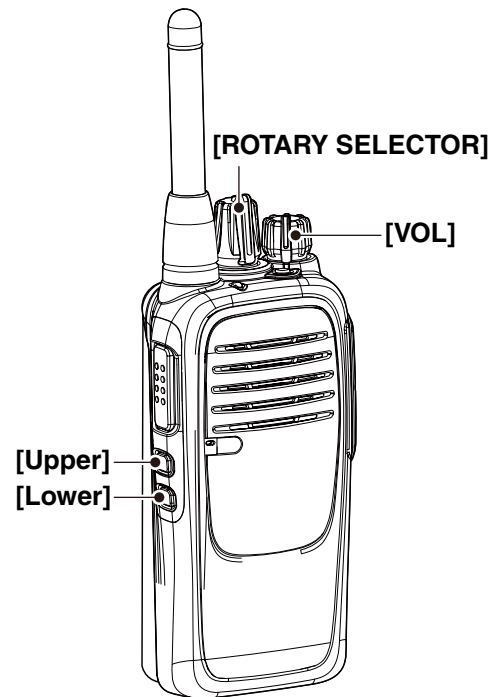

Setting the beep level

You can adjust the beep level between 1 and 5, or 1 (linked) and 5 (linked).

When a linked option is selected, you can adjust the beep level by rotating **[VOL]**.

- ① Rotate **[VOL]** to turn OFF the transceiver power.
- ② Set **[ROTARY SELECTOR]** to any channel other than Channel 16.
- ③ While holding down **[Lower]**, rotate **[VOL]** to turn ON the power and enter the beep level adjustment mode.
 - A beep sounds every time you push **[Upper]**. Therefore, you can determine the current level setting by the increasing loudness of the beep that sounds.
 - To determine if you have selected a linked level, set **[VOL]** to minimum, then push **[Upper]** repeatedly, listening for the loudest beep (level 5). Pushing **[Upper]** once after the loudest beep will select 1 (Linked). Repeatedly push **[Upper]** to select the desired linked level.
- ⑤ Rotate **[VOL]** to turn OFF the power to exit the beep level adjustment mode.

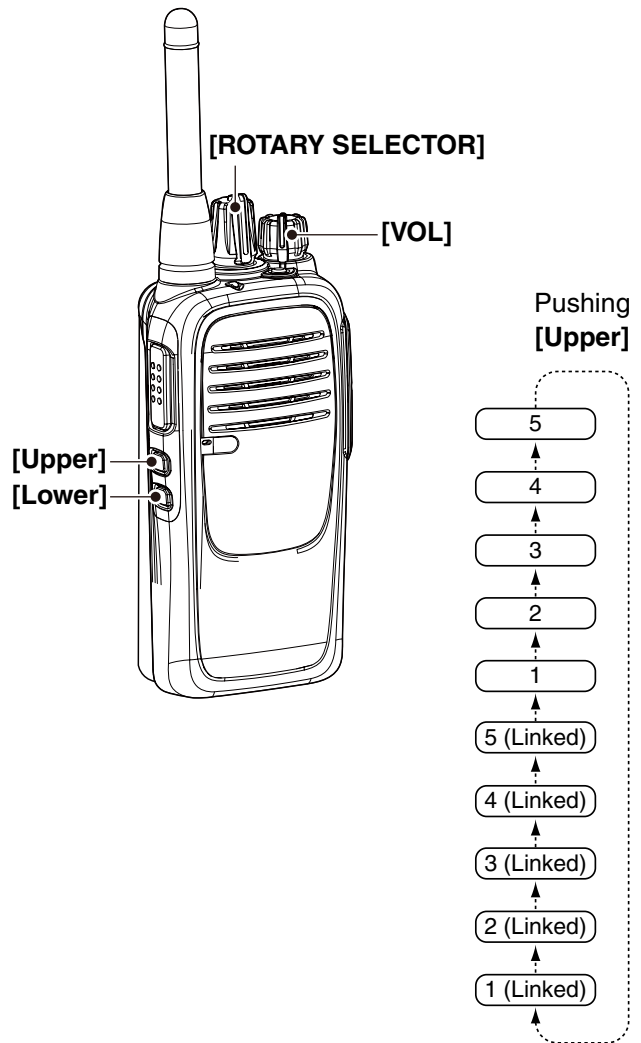

Setting the ringer level

You can adjust the ringer level between 1 and 5, or 1 (linked) and 5 (linked).

When a linked option is selected, you can adjust the ringer level by rotating **[VOL]**.

- ① Rotate **[VOL]** to turn OFF the power.
- ② Set **[ROTARY SELECTOR]** to Channel 16.
- ③ While holding down **[Lower]**, rotate **[VOL]** to turn ON the power and enter the ringer level adjustment mode.
- ④ Push **[Upper]** to increase, or push **[Lower]** to decrease the ringer level as shown to the right.
 - A beep sounds after pushing **[Upper]**. Therefore, you can determine the current level setting by the increasing loudness of the beep that sounds.
 - To determine if you have selected a linked level, set **[VOL]** to minimum, then push **[Upper]** up to 10 times, listening for the loudest beep (level 5). Pushing **[Upper]** once after the loudest beep will select 1 (Linked). Repeatedly push **[Upper]** or **[Lower]** to select the desired linked level.
- ⑤ Rotate **[VOL]** to turn OFF the power to exit the ringer level adjustment mode.

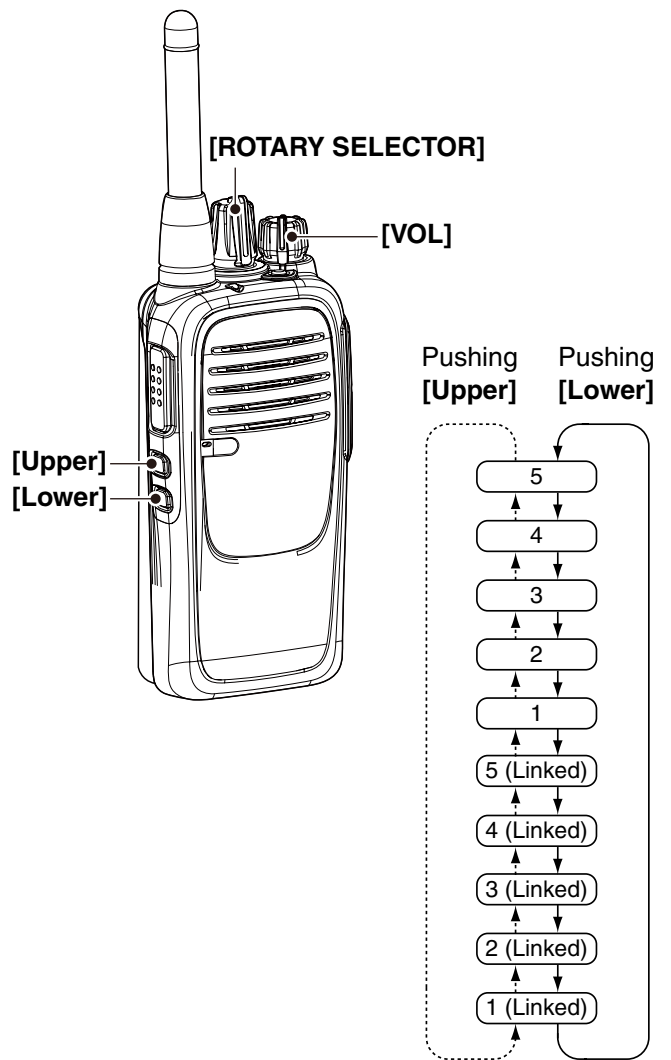

Setting the group code number

◇ CTCSS tone setting

The transceiver is equipped with 50 CTCSS tones. CTCSS operation enables silent standby, since you will only receive calls from group members using the same CTCSS tone.

- ① Rotate **[VOL]** to turn OFF the power.
- ② Set **[ROTARY SELECTOR]** to any channel other than Channel 16.
- ③ While holding down **[PTT]**, **[Upper]**, and **[Lower]**, rotate **[VOL]** to turn ON the power.
- ④ Rotate **[ROTARY SELECTOR]** to select the desired channel (1 to 16) that you want to assign the CTCSS tone to.
- ⑤ Hold down **[Upper]** until two beeps sound.
 - The transceiver enters the CTCSS tone setting mode.
- ⑥ Push **[PTT]** the necessary number of times to enter the ten's digit of the desired CTCSS tone number (grey column) as shown in the list below.
- ⑦ Push **[Upper]**.
 - The selected number will be announced.
- ⑧ Push **[PTT]** the necessary number of times to enter the one's digit of the desired CTCSS tone number (grey column) as shown in the list below.
- ⑨ Push **[Upper]** to complete the setting.
 - The selected number will be announced.
- ⑩ Turn OFF the power to exit the CTCSS tone setting mode.

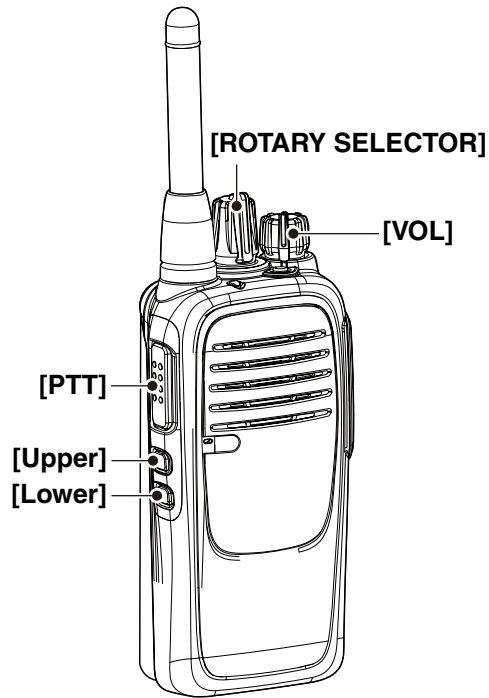

NOTE:

- If you make a mistake, go back to step ① and follow all the steps again.
- If you want to enter “0,” do not push **[PTT]** in step ⑤ and ⑦, just push **[Upper]**. Then “zero” will be announced. To turn OFF the CTCSS tone, enter “00.”

[Example]: CTCSS tone No. 28 (162.2 Hz) assigned to channel 4

- ① Rotate **[VOL]** to turn OFF the power.
- ② While holding down **[PTT]**, **[Upper]**, and **[Lower]**, rotate **[VOL]** to turn ON the power.
 - The transceiver enters CTCSS tone Setting mode.
- ③ Rotate **[ROTARY SELECTOR]** to select channel 4, then hold down **[Upper]** until two beeps sound.
- ④ Push **[PTT]** two times to enter “2” (the ten's digit) of the number 28.
- ⑤ Push **[Upper]**.
 - “Two” will be announced.
- ⑥ Push **[PTT]** eight times to enter “8” (the one's digit) of the number 28.
- ⑦ Push **[Upper]** to complete the setting.
 - “Eight” will be announced.
- ⑧ Turn OFF the power to set the CTCSS tone.

• Available CTCSS tone list

(Hz)

No.	Freq.	No.	Freq.	No.	Freq.	No.	Freq.	No.	Freq.
01	67.0	11	94.8	21	131.8	31	171.3	41	203.5
02	69.3	12	97.4	22	136.5	32	173.8	42	206.5
03	71.9	13	100.0	23	141.3	33	177.3	43	210.7
04	74.4	14	103.5	24	146.2	34	179.9	44	218.1
05	77.0	15	107.2	25	151.4	35	183.5	45	225.7
06	79.7	16	110.9	26	156.7	36	186.2	46	229.1
07	82.5	17	114.8	27	159.8	37	189.9	47	233.6
08	85.4	18	118.8	28	162.2	38	192.8	48	241.8
09	88.5	19	123.0	29	165.5	39	196.6	49	250.3
10	91.5	20	127.3	30	167.9	40	199.5	50	254.1
								00	OFF

Setting the group code number (Continued)

◇ DTCS code setting

This transceiver is equipped with 84 DTCS codes. DTCS operation enables silent standby, since you will only receive calls from group members using the same DTCS code.

- ① Rotate [VOL] to turn OFF the power.
- ② Set [ROTARY SELECTOR] to any channel other than Channel 16.
- ③ While holding down [PTT], [Upper], and [Lower], rotate [VOL] to turn ON the power.
- ④ Rotate [ROTARY SELECTOR] to select the desired channel (1 to 16) that you want to assign the DTCS code to.
- ⑤ Hold down [Lower] until two beeps sound.
 - The transceiver enters the DTCS code setting mode.
- ⑥ Push [PTT] the necessary number of times to enter the ten's digit of the desired DTCS code number (grey column) as shown in the list below.
- ⑦ Push [Upper].
 - The selected number will be announced.
- ⑧ Push [PTT] the necessary number of times to enter the one's digit of the desired DTCS code number (grey column) as shown in the list below.
- ⑨ Push [Upper].
 - The selected number will be announced.
- ⑩ If you want to use Inverse mode, push [PTT] again.
 - If you want to use Normal mode, skip this step.
- ⑪ Push [Upper] to complete the setting.
- ⑫ Turn OFF the power to exit the DTCS Code Setting mode.

NOTE:

- If you make a mistake, go back to step ① and follow all the steps again.
- If you want to enter "0", do not push [PTT] in step ⑤ and ⑦, just push [Upper]. Then "zero" will be announced. To turn OFF the DTCS code, enter "0."

[Example]: DTCS code No. 16 (114) Inverse mode assignment to channel 5

- ① Rotate [VOL] to turn OFF the power.
- ② While holding down [PTT], [Upper], and [Lower], rotate [VOL] to turn ON the power.
 - The transceiver enters DTCS Code Setting mode.
- ③ Rotate [ROTARY SELECTOR] to select channel 5, then hold down [Lower] until two beeps sounds.
- ④ Push [PTT] one time to enter "1" (the ten's digit) of the number 16.
- ⑤ Push [Upper].
 - "One" will be announced.
- ⑥ Push [PTT] six times to enter "6" (the one's digit) of the number 16.
- ⑦ Push [Upper].
 - "Six" will be announced.
- ⑧ Push [PTT] again, to use Inverse mode.
- ⑨ Push [Upper] to complete the setting.
- ⑩ Turn OFF the power to set the DTCS code.

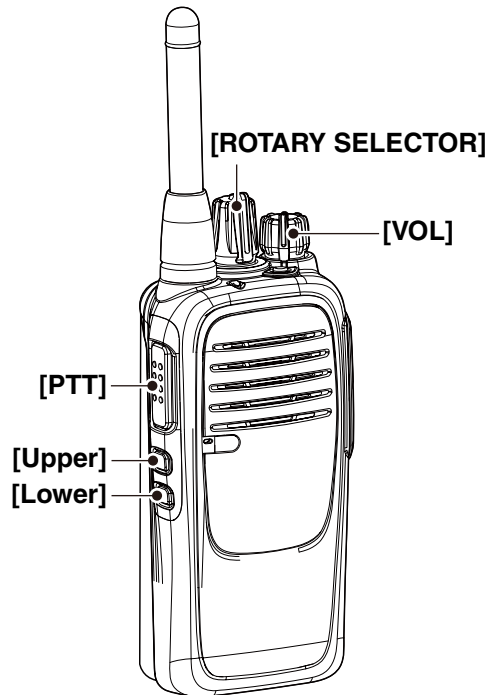

• Available DTCS code list

No.	Code	No.	Code	No.	Code	No.	Code	No.	Code
01	023	21	132	41	271	61	466	81	732
02	025	22	134	42	306	62	503	82	734
03	026	23	143	43	311	63	506	83	743
04	031	24	152	44	315	64	516	84	754
05	032	25	155	45	331	65	532	00	OFF
06	036	26	156	46	343	66	546		
07	043	27	162	47	346	67	565		
08	047	28	165	48	351	68	606		
09	051	29	172	49	364	69	612		
10	054	30	174	50	365	70	624		
11	065	31	205	51	371	71	627		
12	071	32	223	52	411	72	631		
13	072	33	226	53	412	73	632		
14	073	34	243	54	413	74	654		
15	074	35	244	55	423	75	662		
16	114	36	245	56	431	76	664		
17	115	37	251	57	432	77	703		
18	116	38	261	58	445	78	712		
19	125	39	263	59	464	79	723		
20	131	40	265	60	465	80	731		

Setting the microphone gain

Higher levels make the microphone more sensitive to the user's voice.

- ① Rotate **[VOL]** to turn OFF the power.
 - ② Set **[ROTARY SELECTOR]** to Channel 16.
 - ③ While holding down **[Upper]**, rotate **[VOL]** to turn ON the power and enter the microphone gain adjustment mode.
 - ④ Push **[Upper]** or to increase, or push **[Lower]** to decrease the microphone gain.
 - The adjustable range is 1 (minimum) to 4 (maximum).
 - A beep sounds after pushing **[Upper]** or **[Lower]**.
An error beep sounds if you try to exceed the adjustable range.
- ⚡ **NOTE:** The Beep function should be turned ON. (p. 5)
- ⑤ Rotate **[VOL]** to turn OFF the power to exit the microphone gain adjustment mode.

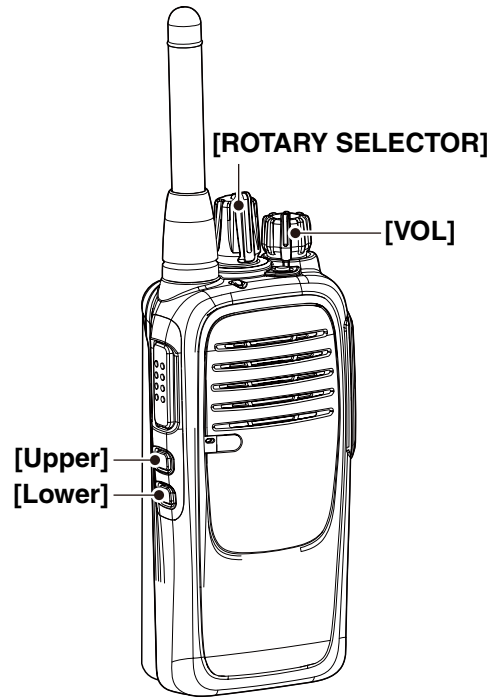

Setting the squelch level

The squelch circuit mutes the received audio signal, depending on the signal strength.

- ① Rotate **[VOL]** to turn the transceiver power OFF.
- ② Set **[ROTARY SELECTOR]** to any channel other than Channel 16.
- ③ While holding down **[Upper]**, rotate **[VOL]** to turn ON the power and enter the squelch level adjustment mode.
 - The adjustable range is 0 (open squelch) and 1 (loose squelch) to 9 (tight squelch).
 - A beep sounds after pushing **[Upper]** or **[Lower]**. An error beep sounds if you try to exceed the adjustable range.
- ⚡ **NOTE:** The Beep function should be turned ON. (p. 5)
- ⑤ Rotate **[VOL]** to turn OFF the power to exit the squelch level adjustment mode.

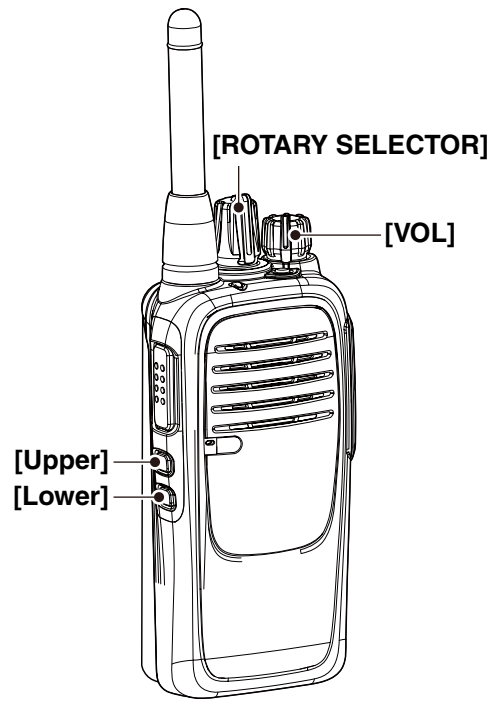

Count on us!