

### Parts

Your P200/300 series wall mounting bracket is supplied with the following items:

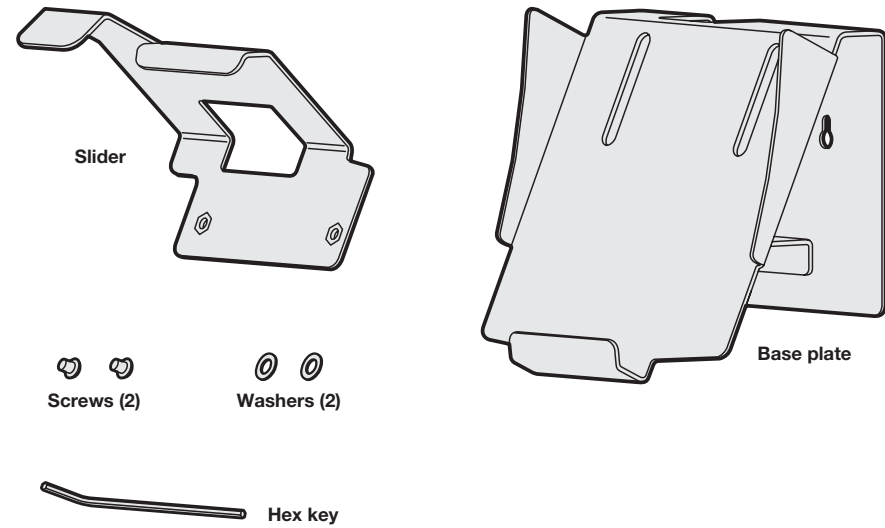

Please see inside for details about assembling and installing your wall mounting bracket.

## Assembly

- 1 Place the Slider onto the Base plate in the orientation shown below, so that the two raised threaded inserts on the Slider locate with the two slots on the Base plate.

*Tip: It is easiest to attach the Slider when the Base plate is lying with its rear plate on a horizontal surface.*

Ensure that the Slider is correctly orientated.

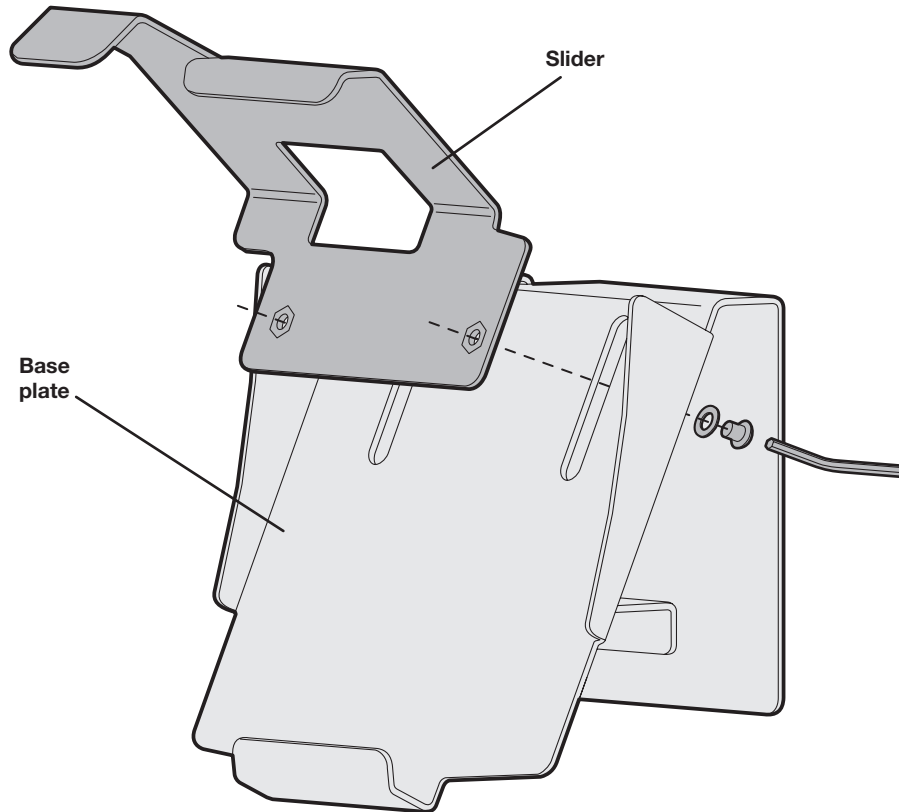

- 2 Place a washer onto each screw.
- 3 The next step requires a little manual dexterity. Position a screw (with its washer in place) behind the front face of the Base plate and introduce it to one of the threaded inserts of the Slider. As the screw engages with the thread of the insert, turn it carefully clockwise until it is held in place. Repeat for the other screw and washer.
- 4 Use the supplied Hex key to tighten the screws such that they still allow the Slider to move within the slots.

## Installation

- 1 Choose a suitable location to mount the bracket where there is a nearby mains power socket and where phone users will have unrestricted access.
- 2 Mark the positions for the fixing holes in either of the following two ways:
  - Raise the Slider to reveal the key holes through the slots in the Base plate. Mark the centres of the two key holes onto the mounting surface.
  - or
  - Make two marks that are horizontally spaced 87mm apart on the mounting surface.
- 3 Use a spirit level to ensure that the two hole marks are absolutely level.
- 4 Drill and plug the holes appropriate to the wall material and the screws used (M3.5 pan head mounting screws are recommended).
- 5 Once the screws are in place, position the base plate on the wall.
- 6 Raise the Slider and tighten the mounting screws using an appropriate screwdriver through the slots. If necessary, use the supplied Hex key to loosen the two adjustment screws from behind the angled Base plate.
- 7 Place the phone onto the angled Base plate.
- 8 Lower the Slider to secure the phone in place and then tighten the two adjustment screws from behind the angled Base plate using the Hex key.

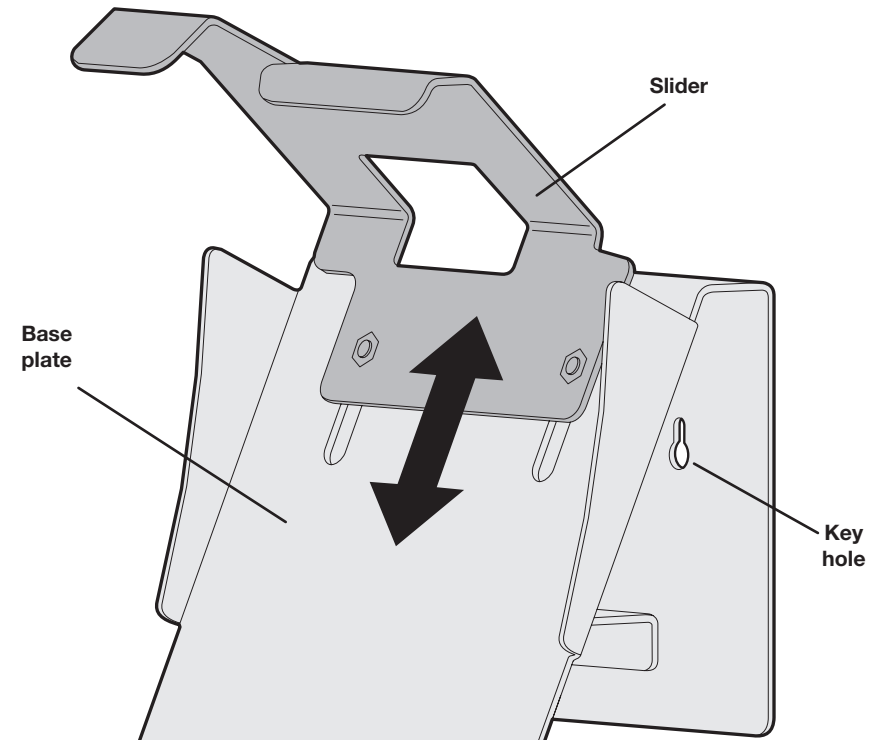

- 9 Connect the cables to the phone as detailed in the Quick Start Guide for the phone. Ensure all cables are secured and do not present a trip hazard.