

# User Manual (*English*)

## EP802 Digital Long Range Cordless Phone



EnGenius Customer Service  
Singapore: 65-62271088, <http://www.engeniustech.com.sg/>

### Table of Contents

Safety Instructions .....	4
General Safety Instructions .....	4
Product Safety Instructions .....	5
Battery Safety Instructions .....	7
Regulatory Information .....	8
Equipment Checklist .....	10
Handset Illustration .....	11
Handset Features .....	13
Basic Handset Features .....	13
Additional Handset Features .....	15
Base Illustration .....	21
Base Features .....	22
Basic Base Station Features .....	22
Charger Illustration .....	23
Charger Features .....	24
Getting Started .....	25
Base Station Installation .....	25
Handset and Charger Installation .....	26
Basic Operations .....	27
Operation Modes .....	27
A. Base Operation Modes .....	27
B. Handset Operation Modes .....	27
Making a Telephone Call .....	29
Making an 2-Way/ Intercom Call .....	29
Making a Broadcast .....	30
A. Handset to Handset Calls .....	30
Redial .....	31
Receiving a Telephone Call .....	31
Receiving an Intercom Call .....	32
Ending a Call .....	32
Adjusting Handset Receiver (Earpiece) Voice Volume .....	33
Adjusting Handset Speakerphone Voice Volume .....	33
Placing a Call On Hold .....	33
Mute .....	34

Do Not Disturb (Silent Ring) .....	34
Key Guard .....	34
Battery Recharge and Replacement .....	35
Advanced Operations .....	36
Handset Registration.....	36
Handset Group Subscription .....	37
Call Transfer.....	38
Phonebook Operations .....	39
Call Barring .....	42
Programmable Feature Call .....	45
Caller ID .....	46
Multi-Base Setting .....	48
Call Manager .....	49
Visual Message Waiting Indicator (VMWI) .....	50
Adjust Handset Microphone Gain.....	50
Adjust Headset Ring .....	51
Baby Monitor .....	51
Index.....	58
Technical Specifications .....	62

## Safety Instructions

**Caution:** *Your wireless telephone gives you freedom and flexibility to stay in touch while you move around. However, when using your phone equipment, safety instructions should be followed to avoid the risks of fire, electric shock, injury to person, and damage to property.*

### General Safety Instructions

1. When using your wireless phone, ensure your safety and the safety of others:
  - a. Always watch where you are walking and standing.
  - b. Don't let a phone call distract you from working safely.
2. In an emergency:
  - a. If an emergency occurs, dial the emergency phone number. Remember: if you are in an area where your phone does not have a clear signal from the base station, it is highly probable that the call may not go through. Locate the nearest landline telephone or other communications device to call for help.
  - b. Emergency calls may not automatically provide emergency personnel with your name, phone number or location.
3. Notice to Hearing Aid Users: This phone system is compatible with inductively coupled hearing aids.
4. Notice to Cardiac Pacemaker Users: Although interference to the implanted cardiac pacemaker may occur when operating very closely, wireless telephones "do not seem to pose a significant problem for pacemaker wearers." However, until more is known, suggests that people with pacemakers may want to take precautions when using or carrying a wireless telephone to ensure that there is ample distance between the telephone and the pacemaker. Do not carry the handset in a breast pocket. If you have any reason to suspect that interference is taking place, turn off your handset immediately.

## Product Safety Instructions

1. Read and understand all instructions.
2. Follow all warnings and instructions including those marked on the product.
3. Changes or modifications to this product not expressly approved by the manufacturer will void the warranty and the CE authorization to operate the equipment. Use only manufacturer provided accessories.
4. Do not use the telephone near water. Never spill liquid of any kind on this product.
5. Unplug the product from the wall telephone jack and power outlet before cleaning. Do not use liquid or aerosol cleaners. Use damp cloth for cleaning.
6. Do not place this product on an unstable cart, stand, or table. The product may fall and cause personal injury or damage to the product or other property.
7. Power Outage: In the event of a power outage, your handset charger will not recharge the handset battery, and the base station will not allow you to make an outgoing call or take an incoming call. Both the charger and the base station require electricity for operation. You should have a telephone that does not require electricity available for use during power outage, or have a temporary backup power supply.
8. Slots or openings in the product's housing are provided for ventilation. These openings must not be blocked or covered. Placing the product on a bed, carpeting, or other similar surface may block these openings and should be avoided. This product should never be placed near or over a radiator or heat register, or in a built-in installation unless proper ventilation is provided.
9. Never push objects of any kind into this product through housing slots/openings as they may damage the product, touch dangerous voltage points or short out parts that could result in fire, electric shock, or injury.
10. This product should be operated only from the type of power source indicated on the marking label. If you are not sure of the type of power supply to your home, consult your dealer or local power company.
11. Do not overload wall power outlets and extension cords as this may result in fire or electric shock.
12. To avoid electric shock or burn, do not disassemble this product. Send this product to an authorized service center when service or repair work is required. Call Customer Service for locations near you. Opening or removing covers may expose you to dangerous voltages, electrical currents or other risks. Incorrect reassembling of the product may cause electric shock when the product is subsequently used.
13. Avoid using the product during a storm. There may be a risk of electric shock from lightning.
14. Do not place the product where persons can step, trip, or fall on it.
15. Do not place conductive objects over or near the antenna.
16. Do not use the product to report a gas leak while in the vicinity of the leak.
17. Do not install the base station or the handset charger near microwave ovens, radios, TV sets, speakers, or other electrical equipment. These appliances may cause interference to the product or experience interference from the product.
18. Unplug the base station or the charger adaptor from the power outlet and refer to an authorized service center under the following conditions:
  - a. If liquid has been spilled into the product.
  - b. When the power supply cord or plug is damaged or frayed.
  - c. If the product has been exposed to rain or water.
  - d. If the product does not operate normally by following the operating instructions.
  - e. If the product has been dropped or housing has been damaged.
  - f. If the product shows a distinct change in performance.

## Battery Safety Instructions

1. Use only manufacturer approved Li-ion rechargeable batteries and charger. Do not use other types of rechargeable batteries or non-rechargeable batteries. The batteries could short-circuit, and the battery enclosure may be damaged causing a hazardous condition.
2. Follow the charging instruction in this manual and instruction labels and markings in the handset and charger compartments.
3. The battery should not be charged in the place where the temperature is less than 0°C or greater than 50°C.
4. Battery must be recycled or disposed of properly. Do not dispose the battery in a fire. The cells may explode.
5. Do not dispose of the battery in municipal waste. Check with local codes for disposal instructions.
6. Exercise care in handling the batteries in order not to short-circuit the battery with conductive materials such as rings, bracelets, keys, pocketknife, and coins. The battery or conductive material may overheat and cause burn or fire.
7. Do not expose batteries to rain or water.
8. Do not open or mutilate the battery. Released electrolyte is corrosive and may cause injury to eyes or skin. The electrolyte may be toxic if swallowed.
9. During charging, the battery heats up. This is normal and is not dangerous.

## Regulatory Information

**EP802**



This device complies with CE Rules. Operation is subject to the following two conditions:

- 1) this device may not cause harmful interference, and
- 2) this device must accept any interference received, including interference that may cause undesired operation.

1. This telephone system complies with rules of the EN 301 357-2 (RF) · EN 301 489 (EMC) · EN 60950 (Safety) and EN 50371 (RF safety).
2. The REN is useful to determine the quantity of devices you may connect to your telephone line and still have all devices ring when your telephone number is called. In most, but not all, areas the sum of the REN's of all devices connected to one line should not exceed 5.0. To be certain of the number of devices you may connect to your phone line, you should contact you local telephone company for the maximum REN in your area.
3. If your telephone equipment causes problems to the telephone network, the telephone company may ask you to disconnect your phone system from the line until the problem has been corrected. Consult with your local phone company for your rights if this happens.
4. Your telephone company may make changes in its facilities, equipment, operations, or procedures that could affect the proper functioning of your telephone system. Consult with your local phone company for your rights if this happens.
5. This telephone system may not be used on coin service provided by the telephone company. Connection to party lines is subject to state tariffs.
6. This telephone system has been tested and found to comply with the limits for rules of the EN 301 357-2 (RF) · EN 301 489 (EMC) · EN 60950 (Safety) and EN 50371 (RF safety). These limits are designed to provide reasonable protection against harmful interference in a general public installation. Operations of these devices may still encounter interference from/to nearby TV's, VCR's, radios, computers, or other electronic devices. To minimize or prevent such interference, the telephone system should not be placed or operated near other electronic devices.
7. However, there is no guarantee that interference will not occur in a particular installation. If this telephone system does cause interference to other electronic

devices, which can be determined by turning the system off and on, the user is encouraged to try to correct the interference by one or several of the following measures:

- a. We recommend at least 20 feet between the system and other electronic devices.
- b. Connect the base station to a power outlet on a circuit separate from that used by the device experiencing interference. Consult the dealer or an experienced electronic technician for help.

## Equipment Checklist





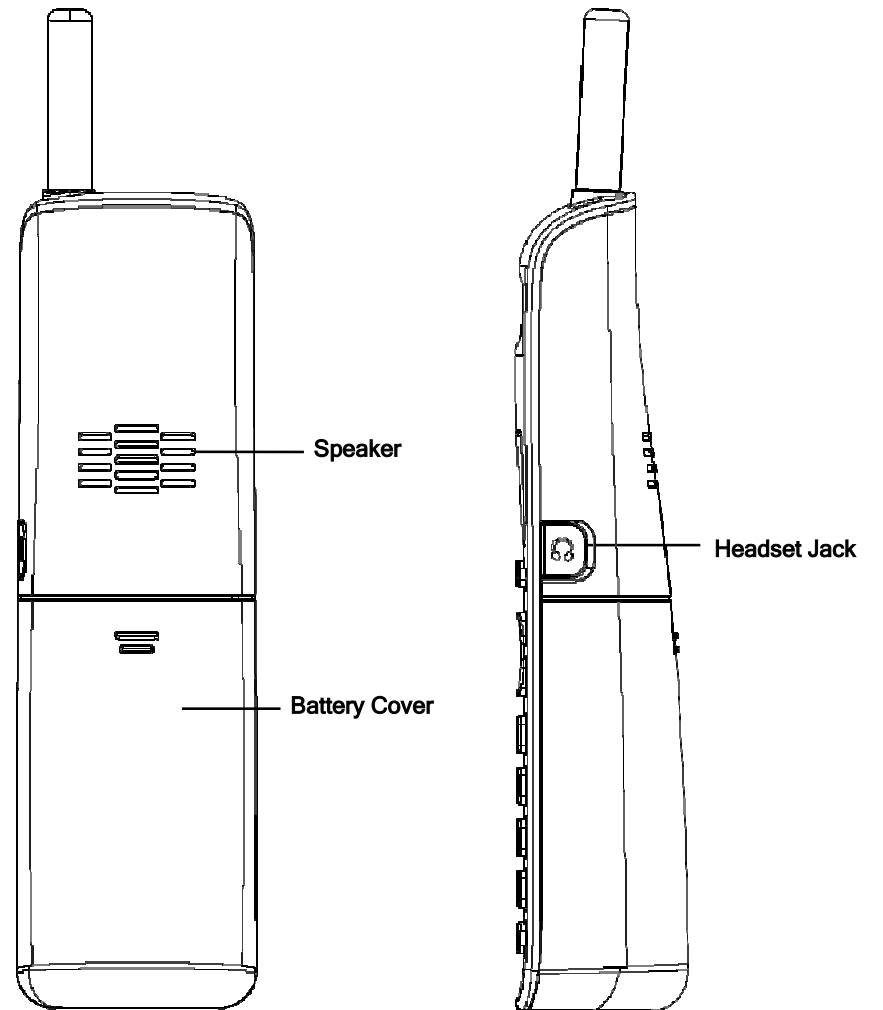
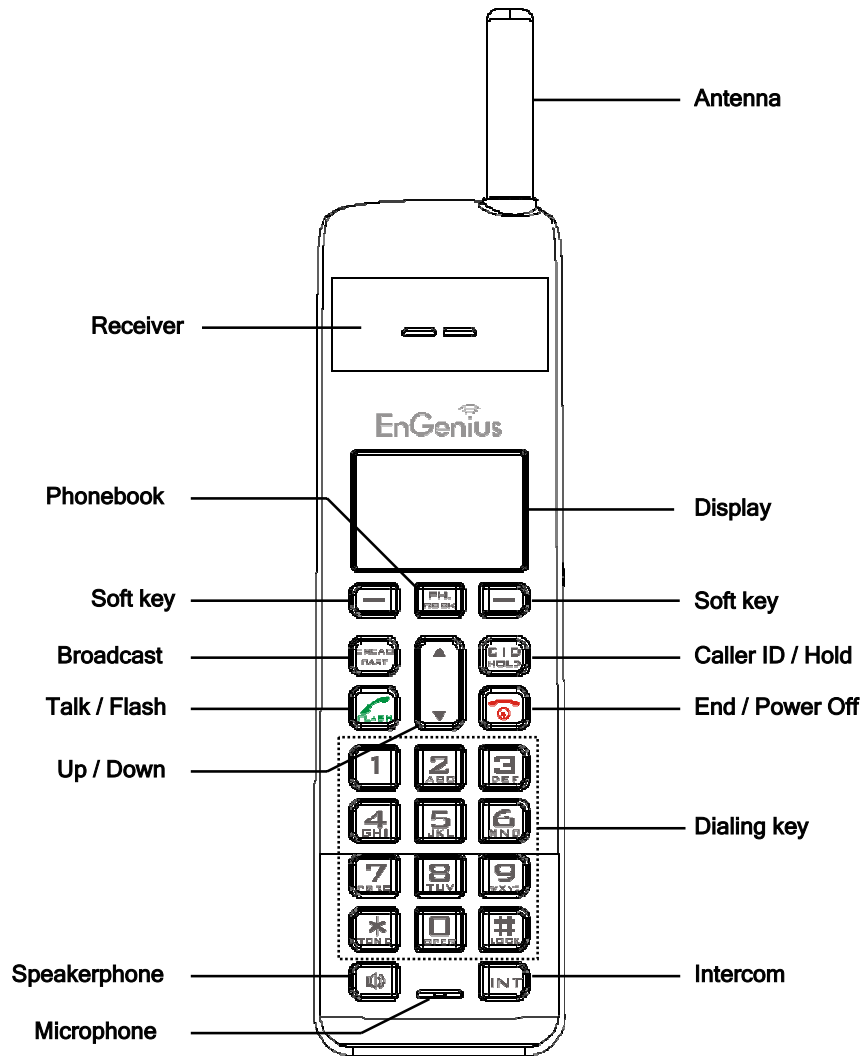







1. In a Base + Handset package, please find the following components:
  - a. Base Station x 1 (antenna installed)
  - b. Base AC/DC Adaptor x 1
  - c. Handset x 1 (antenna installed)
  - d. Handset Antenna x 1 (Long x1)
  - e. Desktop Charger x 1
  - f. Charger AC/DC Adaptor x 1
  - g. 1100mA Li-ion Battery Pack x 1
  - h. Telephone Cord x 1
  - i. CD (User's Manual), Quick Guide
  
2. In a Handset package, please find the following components:
  - a. Handset x 1 (antenna installed)
  - b. Handset Antenna x 1 (Long x1)
  - c. 1100mA Li-ion Battery Pack x 1
  - d. Desktop Charger x 1
  - e. Charger AC/DC Adaptor x 1
  - f. Quick Guide
  
3. Optional Accessory
  - a. Outdoor Antenna Kit (including antenna and cable)
  - b. Lightning Protection Kit
  - c. High-gain handset antenna
  - d. Headset
  - e. Antenna Splitter

# Handset Illustration









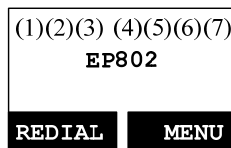



## Handset Features



### Basic Handset Features

1. 4-line LCD (Liquid Crystal Display)
  - a. The LCD display has LED (Light Emitting Diode) for backlighting.
  - b. The 1<sup>st</sup> line of LCD consists of icons.
  - c. Icons explanation from left to right
    - (1) **RSSI level** (Receive Signal Strength Indicator)  
 During a call, the number of bars is proportional to the radio signal strength received.
    - (2) **Link mode**  
 **(2.1) Call in-progress** (ON/OFF-Hook)  
 The number on the right side of phone symbol indicates which the phone line of Base Station is active if Multi-Base is on.  
 **(2.2) Intercom in-progress**  
 Indicates if Intercom mode is active  
 Indicate the Handset ID which is making intercom with.
    - (3) **Speech mode**
      -  **(3.1) Speaker Indicator**  
 Indicate if the speaker is active
      -  **(3.2) Headset mode**
    - (4) **Sound and Indication**
      -  **(4.1) Enable ringer**
      -  **(4.2) Disable ringer**
      -  **(4.3) Ringer and vibrate mode**
      -  **(4.4) Vibrate mode**
      -  **(4.5) Message waiting indicator**
    - (5) **Disable PA**  
 Indicate if the incoming broadcast is disabled.
    - (6) **Two-Digit Handset ID**  
 Displays the 2-digit Handset ID of own.
    - (7) **Battery Strength**  
 Number of bars is proportional to the amount of battery time remaining.
  - d. The 2<sup>nd</sup> and 3<sup>rd</sup> lines of the LCD, maximum 16 characters each, display status, message, menu selections, or user-editable alphanumeric characters.
  - e. The last line displays the left and right soft keys.



2. Ringer
  - a. Rings to an incoming call and intercom call.
  - b. Distinctive alert sounds indicating various events:
    - (1) Single beep: successful key entry.
    - (2) Double beep: indicates power on/off.
    - (3) Triple beep: failed operation.
    - (4) Periodic 1-Long-2-Short beep (every 1 minute): low battery warning · out of range · call on hold
 Re: No any beep for invalid key entry
3. TALK/FLASH 
  - a. Places or answers a telephone or intercom call
  - b. Sends a Flash signal to phone line to retrieve a dial tone after the call ends, or to perform the call waiting feature provided by local phone companies during a call.
4. SPEAKERPHONE 

Press the key to enable/disable the speakerphone during incoming, outgoing or intercom call.
5. 2-WAY INTERCOM 
  - a. Places an intercom call to another handset, a group handset (group paging) or all registered handsets.
  - b. Intercom calls are digital, full duplex, and are conducted without the assistance from the base station.
6. BROADCAST 
  - a. Half duplex broadcasting to handsets for immediate announcement
  - b. Half duplex broadcasting to base stations
 Re : Press the  key on the left top corner of handset to activate the broadcast function.
7. Left/Right Soft Keys  
  - a. Make menu selection.
8. Up  /Down  Scrolling Keys
  - a. Scroll through records and menu selections.
  - b. Adjust receiver voice volume when in the Talk mode.
  - c. Press  to adjust ringer volume when in the Standby mode.

- d. Press  to enter phonebook when in the Standby mode.
9. END; On/Off Key 
    - a. Ends a call.
    - b. Leaves current menu operation, up one level.
    - c. Press for 3 seconds to off the power
  10. CALLER ID Key 
    - a. Review caller ID list.
    - b. Including received and missed caller ID.

### Additional Handset Features

1. Multiple handsets registration
  - a. Up to 9 handsets can be registered to a base station
  - b. ID 11-19: individual Handset IDs.
  - c. ID 91-99: Group IDs. Handsets can “subscribe” from the handset menu to group(s) and be paged when a landline caller or an intercom caller enters a Group ID.
2. Ringer Vibrator
  - a. Two options for Line (incoming call) ringing & Intercom ringing.
  - b. Six-level ringer volume selections (Off/Low/Medium/High/Vibrate/Vibrate & High) for each option.
  - c. Eight ringer type selections for each option.
3. Caller ID
 

Displays incoming call phone number and name on the LCD (needs Caller ID service from local telephone company)
4. Call waiting with caller ID
 

Displays 2<sup>nd</sup> incoming call information on the same phone line when 1<sup>st</sup> call is in progress (needs Call Waiting with Caller ID service from local telephone company)
5. Name tagging with caller ID
 

Match the caller ID with the phone book entries; once matched, the LCD screen will display the name or nickname instead of pure caller ID info (needs Call Waiting with Caller ID service from local telephone company).
6. DND (Do Not Disturb, i.e., Silent Ring)

7. Call Logs
  - a. Redial: Stores 10 phone numbers (up to 26 digits each) dialed most recently. Can perform last-number redial on all 10 numbers.
  - b. Received & New Call Log: Total 50 entries (16-digit phone number, 16-character names, and Date/Time stamp), needs Caller ID service from local telephone company.
  - c. Phone numbers and names can be saved into phonebook while in display.
8. Call Barring: Block outgoing call and incoming call.
  - a. Outgoing call:
    - a-1. Block the users from dialing long distance calls or international calls
    - a-2. Up to 5 digits of each call barring setting; up to 5 entries allowed.
  - b. Incoming call:
    - b-1. PA On/Off: Enable or disable the broadcast from other handsets or base station. When PA is Off, the handset can't receive broadcast from base station or other registered handsets, but it can broadcast to base station or other registered handsets.
    - b-2. Line On/Off: Enable or disable the capability to receive incoming call from telephone line. When Line is Off, the handset can't receive incoming call from telephone line, but it can still make outgoing call.
    - b-3. Int. On/Off: Enable or disable the intercom from other handsets or base station. When Int. is Off, the handset can't receive intercom from base station or other registered handsets, but it can intercom to base station or other registered handsets.
  - c. This changing requires to entering the “Call Settings” (MENU-4-3). [Note] You need to key in the accurate user ID and password to perform this feature. The default password is “0000”.
9. Any Key Answer (except  and **SILENT** Soft Key)



10. Key-guard
  - a. When the keyguard is selected, all keys will be locked. Press **UNLOCK** (Left) soft key followed by "\*" to release it.
  - b. The keyguard will be automatically enabled once returning back to idle mode for 15 seconds.
11. Dialing Prefix
  - a. Up to 14 digits, including pause(s), one access code can be pre-programmed to be added automatically in front of the dialed number when dialing from call logs, phonebook, and dial-and-send dialing.
12. Call Hold
  - a. Places call on hold
13. Mute
  - a. Press **MUTE** (Left) soft key during talk, the handset microphone will be muted. Press **UNMUTE** (Left) soft key to release it.
14. Phonebook
  - a. 50 entries, each stores a phone number or handset ID (up to 26 digits) and name (up to 16 characters)
  - b. Alphabetically sorted display and search by letter.
  - c. Dial from display.
  - d. During the stand-by mode, you can enter the phone book by pressing  scrolling key.
  - e. Phone book transfer via air
    - i. Transfer specific phonebook to one handset or all registered handsets
    - ii. Transfer all phonebooks to one handset or all registered handsets
15. Key tone
  - a. Four-level key tone volume selections (Off/Low/Medium/High).
  - b. Four key tone type selections.
16. Call Timers
  - a. Display call time duration for current call during and immediately after the call.
17. Programmable Feature Call
  - a. Allow user to pre-program the most frequently used Feature code into EP802 which is adjunct to the PBX system.
    - b. Up to 10 entries can be saved.
    - c. Once the feature code is being programmed, you can quickly perform those functions during the call by pressing **OPTION** soft key.
18. Menu Display
  - a. To avoid mis-setup in the "Call Settings" (**MENU-4**), "Phone Settings" (**MENU-5**), "Base Settings" (**MENU-6**) and Multi-base Setting (**MENU-7-3**), these settings can be hidden.
  - b. Handset password is required before enter Menu Display (**MENU-8**), the default handset password is "0000".
  - c. When disabling the settings, these setting will not displayed any longer, unless enabled by entering Menu Display again.
19. PA On/Off
  - a. Enable or disable the broadcast function.
  - b. When PA is Off, the handset can't receive broadcast from base station or other registered handsets; But it can broadcast to base station or other registered handsets.
20. Group Setting
  - a. Allow handset to subscribe to one or several groups.  
Re: Up to 9 groups (91~99) can be subscribed.
21. Custom Name
  - a. Allow changing the "EP802" screen to the desired wording or info, such as the user's name.  
Re: Up to 32 characters can be entered.
22. Change Pwd
  - a. Allow changing the handset password which requires entering in Call Barring (**MENU-4-3**) and Menu Display (**MENU-8**).  
Re: Default is "0000".
23. DTMF Duration
  - a. From **MENU-6-1** to select variable duration of DTMF tone.
  - b. Default is 100ms.
  - c. When entering the Base Settings, PIN is required. Default is "0000".  
Re: Better to check with your phone company first before changing it.

24. Programmable Flash key timing
  - a. From **MENU-6-2** to select flash key timing
  - b. 9-level (100 ms - 900 ms) timing selections, default= 600 ms.
  - c. The default value (600 ms) works in most areas. Changing this setting may cause Flash key not working. Change only when you are certain of the new value would work.
  - d. When entering the Base Settings, PIN is required. Default is "0000".
  
25. Assign next handset ID for new handset
  - a. Using registered handset from **MENU-6-3** to assign a next handset ID to a new handset.
  - b. If not assign next handset ID, the system will automatically assign a handset ID to a new handset..
  - c. When entering the Base Settings, PIN is required. Default is "0000".
  
26. Clear Handset
  - a. Using registered handset from **MENU-6-4** to remove the other registered handset, in case the other registered handset is defected.
  - b. Once clear the other registered handset, the user is able to register a new handset for instead.
  - c. When entering the Base Settings, PIN is required. Default is "0000".
  
27. Change PIN
 

Allow changing the base PIN which requires entering the "Base Settings" (**MENU-6-5**).



  - a. Using registered handset to change PIN from **MENU-6-5**.
  - b. Default PIN is "0000".
  - c. When entering the Base Settings, PIN is required. Default is "0000".
  
28. Auto Hang Up feature
  - a. Using registered handset from **MENU-6-6** to turn on/off the Auto hand up feature.
  - b. If turning on the feature, the handset will automatically hang up the call when the far-end hangs up the call.
  - c. When entering the Base Settings, PIN is required. Default is "0000".
  
29. Area Code
 

The area code function allows calls within local and country area codes to be dialed without the prefix.

  - a. Enter **MENU-4-7-1** to set the "Local" area code.
  - b. Enter **MENU-4-7-2** to set the "Country" area code.  
Re: Up to 3 digits can be entered.

30. Multiple Base setting
  - a. Up to 4 base stations can be set in one system.  
Re: For best performance, maintain a distance of at least 5 meters (about 15 feet) between any two base stations.
  
31. Set Time
 

The set time function allows user to set date/time to support the DTMF caller ID (DTMF caller ID doesn't attach date/time when receiving from PSTN, using this setting, user is able to review the date/time when the caller ID received).

  - a. Enter **MENU-6** to set Base Settings.
  - b. Press  or  scrolling key to select desired base station when Multi-Base is set.
  - c. Enter Base PIN (Default is "0000").
  - d. Enter "7" to enter Set Time.
  - e. Enter 4 digits for MM/DD(Month/Day), then enter 4 digits for hr:mm (Hour : Minute)
  - f. Press **SAVE** (left soft key) to finish the setting.
  
32. Mic Gain
 

Allow changing the handset microphone gain based on the handset in different environment – Quiet, Normal and Noisy environment.  
This requires entering the "Phone Settings" (**MENU-5-1**).
  
33. Headset Ring
 

Allow changing the ringer emitted either from handset speaker or receiver of headset.  
This requires entering the "Phone Settings" (**MENU-5-9**).
  
34. Baby Monitor
 

Allow setting the handset monitoring the baby room via intercom call. When setting Baby Monitor ON, this dedicated handset will not answer any incoming call, except the 2-way intercom.  
This requires entering the "Call Settings" (**MENU-4-5**).

## Base Illustration

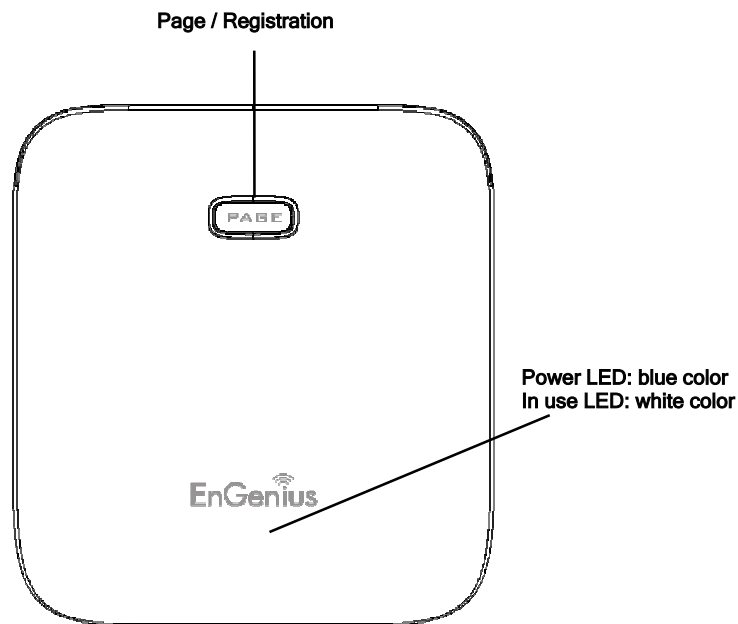

## Base unit Diagram

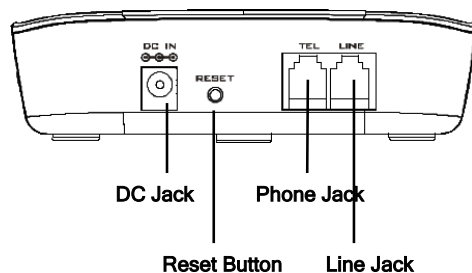

## Base Features

### Basic Base Station Features

1. Antenna
  - a. The antenna port has a **normal thread connector**; to remove antenna or cable, turn counterclockwise; to install, turn clockwise. Improper installation may damage the connector.
  - b. When using an outdoor antenna, locate the antenna (not the base station itself) as high as possible for a clear transmission path.
2. LED
  - a. Power (blue color): it indicates base station has power.
  - b. In-Use (white color): it indicates an active telephone line.
3. RESET Button
  - a. Restores base station to factory settings
  - b. Reset button is intended to prevent accidental system reset.
  - c. All handsets (including administrator) and additional base(s) need to be re-registered after a base station reset.
4. Page Button (PAGE)

To search a misplaced handset; press "PAGE" button, all registered handsets beep for 30 seconds.  
Press "PAGE" again or any key on handset to stop.
5. Registration Button (PAGE)

Enters registration mode along with handset, assigns handset ID (11-19).
6. Line Jack  
Standard RJ-11C/CA-11A connector to plug in the telephone line
7. Telephone Jack  
Another RJ-11C to plug in the optional answering machine
8. DC In: to plug in the power adaptor

## Charger Illustration

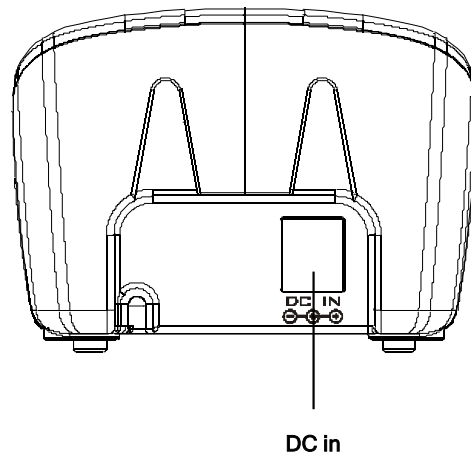
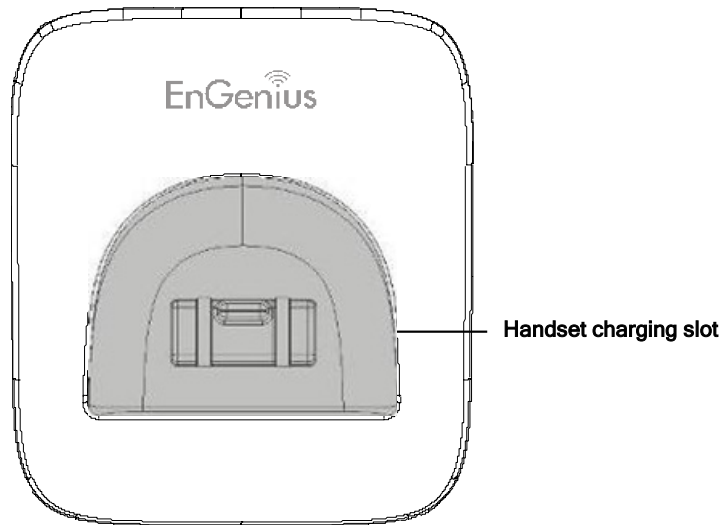

## Charger Features

1. DC In  
Connects to Charger AC Adaptor.
2. Handset Charging Slot
  - a. Charge handset battery when handset is placed in cradle.
  - b. Refer to the handset LCD for charging status
    - (1) Charging: battery status bar is running and the LCD screen showed "Charging".
    - (2) Fully Charged: battery status bar stands still and the LCD screen would display "Charge Complete"
    - (3) Charge Fail: Should there be any error occurred during charging mode, the LCD screen would display "Charge Fail"
3. It is impossible to overcharge the battery using this charger.
4. The adaptor for charging station can be used as travel charger as well. However, you can't turn off the power while you charge the handset via travel charger. A warning message "Unplug Travel Charger then OFF" will be shown on the LCD.

### Notes:

1. Fully charge battery packs before first use.
2. Handset will be "power on" automatically when placing on the charging slot.
3. However, if you run drain the battery, it will take around one minute for handset to auto power on.

## Getting Started

### Base Station Installation

There are three possible base station setups:

- Base station alone
- Base station plus telephone answering device
- Base station plus standard telephone

For best performance, maintain at least a distance of 1 meter (about 3 feet) between the base station and other electronic devices (e.g., TV, computer, stereo, fax machine, answer machine, cordless phone, etc.)

1. Install base station antenna.  
The base station's antenna port has a **normal-thread connector**; to install antenna or cable, turn clockwise; to remove, turn counter-clockwise. Improper installation may damage the connector.
2. Plug the transformer end of the base station AC/DC adaptor into a standard AC electrical power outlet, plug the other end into the "DC In" jack on the back of the base station.
  - a. The base adaptor's DC plug is same dimension as the charger's DC plug. The charger adaptor's DC plug can fit into the base's DC In jack.
3. Plug phone cord into the "LINE" Jack
4. A standard telephone or answering machine can be plugged into the adjacent jack on the back of the base station marked TEL

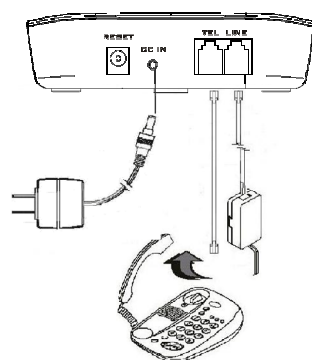

### Handset and Charger Installation

1. Plug the transformer end of the Charger AC/DC adaptor into a standard AC electric power outlet, plug the other end into the "DC In" jack on the back of the Charger.
2. Install battery pack onto the handset.
3. Install handset antenna.
4. Place handset onto the charger slot.
5. Fully charge the battery for three hours before use.
6. The phone system is now ready to perform basic functions such as making and receiving phone calls and intercom calls. No base station or handset programming is needed for basic operations.

#### Note:

1. Handset(s) packaged along with a Base Station are pre-registered at the factory. If you have a new handset, you will need to register the handset with the base station in order to be recognized as a member handset by the base(s) and by other handsets. See Handset Registration.
2. Fully charge battery packs before the first usage.

## Basic Operations

### Operation Modes

Both the base station and handset have levels of operation at which time only certain procedures of functions can be performed.

#### A. Base Operation Modes

1. **STANDBY mode**- this is the default mode. The page key is active in standby mode only. The base "Power" (blue color) LED will light up during this mode.
2. **TALK mode**- the base station operates in this mode during phone call. The "In Use" (white color) LED will light up during this mode.
3. **REGISTRATION mode**- the base station enters this mode by pressing the PAGE button for three seconds. The "Power" (blue color) LED will be blinking in "Registration" mode, also a prompt sound will be emitted.

#### B. Handset Operation Modes

1. **STANDBY mode**- this is the default mode.
  - a. If there is no on-going activity, the handset automatically goes into SLEEP/STANDBY mode to save battery power.
  - b. The handset can be turned off completely by holding down the  key for 3 seconds.
  - c. The standby screen display (custom name) can be edited.
  - d. The 2-digit number represents the handset ID
2. **MENU mode**
  - a. Press the Right soft function key to activate Menu mode.
  - b. In Menu mode, the handset settings and information contained in memory can be changed.
  - c. The functions available through the Menu selection are covered in greater detail from page 53.
  - d. The Menu structure display as below:

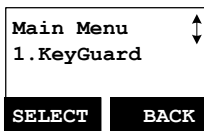

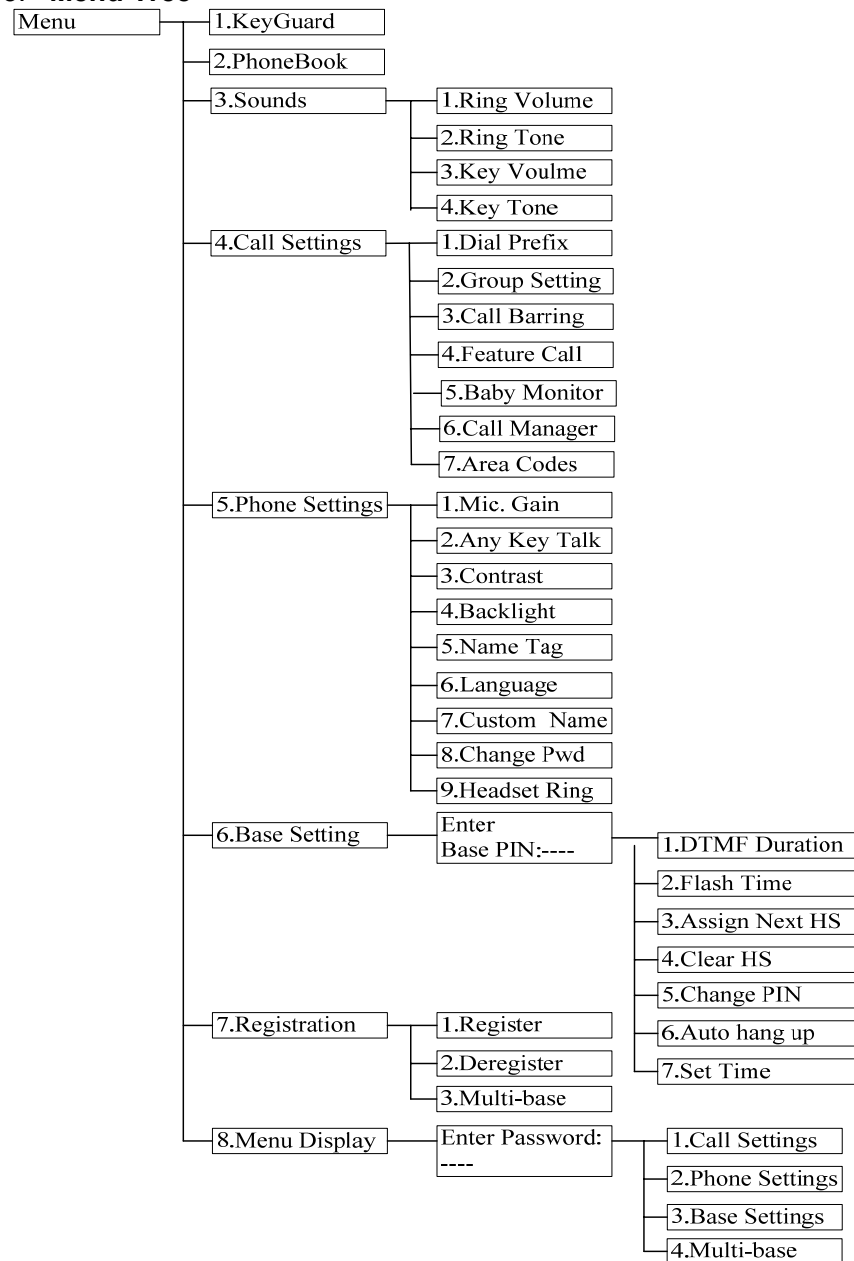

### 3. Menu Tree

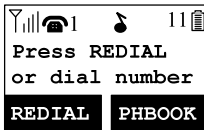

## Making a Telephone Call

1. Press , wait for dial tone, and then enter phone number.





2. Alternatively, you can enter phone number first then press  key.

When using this method, you can use the **CLEAR** (Left) and **DELETE** (Right) soft keys to edit the number entered. "Delete" erases the last digit entered. "Clear" erases the entire line but remains in the dial-and send dialing.



3. **Speed dial** by access the entries in the phone book (Menu→2)

a. Press  or  scrolling key to enter the phone book

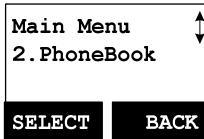

b. Press  to dial out the number

4. To abort dialing, press  key.

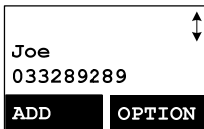

### Notes:

1. If a link cannot be established, the LCD will show "Base not found" after a 6-second time out.
2. A call duration timer will start displaying the length of the call after link is established.

## Making an 2-Way/ Intercom Call

The EP802 Cordless Phone System offers private, Intercom/ 2-way radio calls independence of base station. Intercom/ 2-way communication can be placed between handsets.

1. Press  key followed by a two-digit handset ID or Group ID.

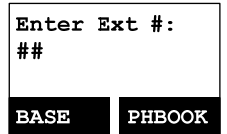

2. Press  key to end the call.

### Notes:

1. Intercom calls can be made regardless if the Base Station is present.
2. If a Group ID is entered, the first handset (belonging to that group) that answers will establish a link with the caller. See Handset Group Subscription.
3. If a link cannot be established, the LCD shows "Paging timeout" after a 35-second time out.

## Making a Broadcast

### A. Handset to Handset Calls

1. Broadcasting all handsets

a. Press and hold  key (left top corner of keys) from one handset.

b. Hear a long "Du..." sound while the initiating handset broadcasting to all handsets within communication coverage.

c. Start to speak the message to be broadcasted once you hear the "Du Du" sound; the speakerphone of destination handsets will be opened up. if it received the voice.

Re: the initiating handset press and hold the  key is needed during the speaking or broadcasting.

d. Release  key to end the broadcasting.

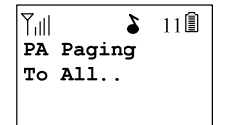

2. Broadcasting a group of handsets

a. Enter the Group ID and then press and hold  key (left top corner of keys).

b. Hear a long "Du..." sound while the initiating handset broadcasting to all handsets.

c. Start to speak the message to be broadcasted once you hear the "Du Du" sound; the speakerphone of destination handsets will be opened up. if it received the voice.

Re: the initiating handset press and hold the  key is needed during the speaking or broadcasting.

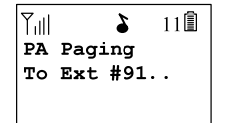



d. Release  key to end the broadcasting.

### 3. Broadcasting an individual handset

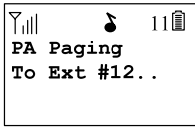
- Enter the Handset ID and then press and hold  key (left top corner of keys).
- Hear a long “Du...” sound while the initiating handset broadcast all handsets within communication coverage.
- Start to speak the message to be broadcasted once you hear the “Du Du” sound; the speakerphone of destination handsets will be opened up. if it received the voice.



Re: the initiating handset press and hold the  key is needed during the speaking or broadcasting



d. Release  key to end the broadcasting.

### Redial

1. Press **REDIAL** (Left) soft key.

2. The LCD shows the last phone number dialed. To dial this number, press  key.



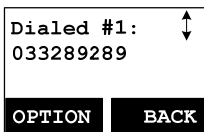

3. Use  or  key to scroll through the last 10 phone numbers dialed. Select and press  key to dial the selected number.  
[Note] Intercom numbers (Handset ID) are not stored in the last 10 numbers dialed log.

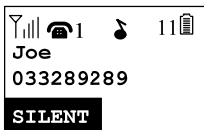

### Receiving a Telephone Call

1. When an incoming call arrives, the LCD will show the caller ID message, and the ringer will ring or vibrate unless the ringer has been turned off.



2. If the handset is on the charger cradle (ringer will be temporarily switched to “Ring” if it has been set to “Vibrate”), lift the handset and press  key to start

conversation.

Re: You can turn on the “Any Key Talk” from **MENU-5-2**

#### Notes:

- You can press **SILENT** (Left) soft key if you choose to ignore the call. Unlike turning off the ringer (from the handset menu), the **SILENT** key operation is valid only for the current call.
- If Caller ID service is available, the LCD will display the incoming call information. If the LCD shows “Private” or “Unknown”, the caller’s information may have been blocked by the caller or the originating phone company.

### Receiving an Intercom Call

1. When an intercom call arrives (called from other handsets, ex. Handset 12), the ringer will ring or vibrate unless the ringer has been turned off. Press  to answer the intercom call.

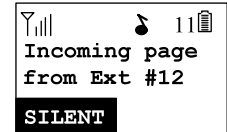

2. If the handset is on the charger cradle (ringer will be temporarily switched to “Ring” if it has been set to “Vibrate”), lift the handset and press  key to start conversation.

3. If the handset is not on the cradle and **MENU-6-2** “Any Key Talk” setting is “On”, press any key (except  and the **SILENT** soft key) to answer.

#### Notes:

- The LCD displays the caller’s Handset ID.
- You can press the **SILENT** (Left) soft key if you choose to ignore the call. Unlike turning off the ringer the **SILENT** key operation is valid only for the current call.



### Ending a Call

To end a telephone or intercom call, press  key, or place handset into





charger cradle.

### Adjusting Handset Receiver (Earpiece) Voice Volume

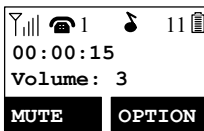
1. Voice volume can only be adjusted during a call.
2. There are 6 levels of volume selections. Use  or  key to adjust
3. The new setting remains effective for all future calls until changed.



### Adjusting Handset Speakerphone Voice Volume

1. Voice volume can only be adjusted during a call (in speakerphone mode).
2. There are 6 levels of volume selections. Use  or  key to adjust
3. The new setting remains effective for all future calls until changed.

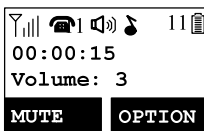



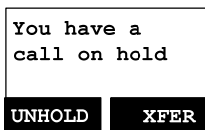

### Placing a Call On Hold

1. When a call is in progress, it can be put on hold by pressing the  key.
2. To return to the conversation, press **UNHOLD** (Left) soft key



#### Notes:

1. The call being placed on hold can be "un-hold" by the handset that puts it on hold. But if the handset press  key to go back standby, then other handsets can press  or  to pick this held call (If press  on base, it can also pick up this held

- call).
2. Handset LCD displays a call is being on hold. An alert tone (double beep) every 30 seconds will remind the handset that a call is being on hold.
3. If the operation (e.g., call transfer) after putting a call on-hold fails, the held call may be dropped.

### Mute

1. After a link is established, you can press **MUTE** (Left) soft key to mute the handset microphone.
2. When mute is active, the other end will not hear your voice, but still can speak to you.
3. To leave the mute state, press **UNMUTE** (Left) soft key. Mute is effective only for the current call.

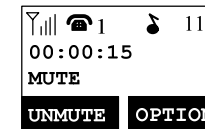

### Do Not Disturb (Silent Ring)

1. Enter the key sequence **MENU**-3-1, then select "Off". Press **SELECT** (Left) soft key to confirm your choice. This will turn off the ringer until it is turn on again from the menu.  
Re: When setting the ringer "Off", the standby screen will show "Ringer off".
2. For temporary silencing the ringer when an incoming call arrives, press **SILENT** (Left) soft key.

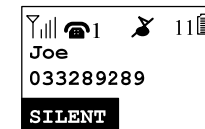

### Key Guard

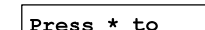
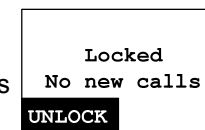

1. To prevent accidental dialing, you can press **MENU** (Right) soft key, then press "1" to select KeyGuard option. The handset keypad is locked. No key entry is accepted.
2. To unlock the keypad, press **UNLOCK** (Left) soft key,



then, within 2 seconds, press the digit “\*” to unlock.

3. Once returning back to standby mode for 15 seconds, the keyguard will be automatically enabled.
4. Key Guard is in effect until unlocked.

### Battery Recharge and Replacement

1. Charge the battery when one or several of the following happen:
  - a. Phone beeps twice (every 60 seconds in talk mode, every 10 minutes in standby mode).
  - b. Battery icon is empty.
  - c. Phone does not respond when a power on/off key  is pressed.
  - d. LCD and backlighting become dim.
  - e. Talk range shortfall is experienced.
2. You can replace the handset battery after placing the call-in-progress on hold and press  key. To retrieve the call on held, press talk key again after replaced battery and power the handset on..
3. Battery talk time and standby time vary depending on the talk/standby pattern and the operating distance. Putting the handset back to charger cradle as often as possible is recommended for best performance. **Use only manufacturer provided battery and charger!**

## Advanced Operations

### Handset Registration

1. If your handset(s) is purchased as part of a system, it has been pre-registered with the base station at the factory.
2. If Handset ID as “00,” that means it is a new handset or the ID has been erased. You need to register the handset with the base station.

#### 3. Registration:

- a. Press **MENU**-7 to enter the registration mode
- b. Press and hold the base's PAGE button for 3 seconds until the In Use LED (white color) lighting up and flashing, also the base station will emit prompt sound to remind you the base station is in the registration mode..
- c. Press handset key “1”, this completes the registration process. The base station will assign a handset ID between 12 and 19 automatically. The assigned ID will be displayed on the handset LCD, indicating successful registration.



- d. Repeat above steps for all additional handsets.

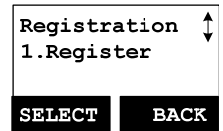

#### 4. De-registration:

- a. You can de-register the handset you're using from the base station. De-registration will reset the Handset ID to 00, erase the system security code, and free up the handset ID for future registration.

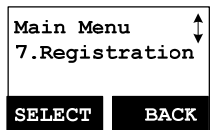

- b. After deregistration, the handset will not be able to use the base station to make or receive phone calls, nor can it intercom other handsets.

- c. Press **MENU**-7 to enter the registration mode
- d. Press and hold the base's PAGE button for 3 seconds until the In Use LED (white color) lighting up and flashing, also the base station will emit prompt sound to remind you the base station is in the de-registration mode.



- e. Press the handset number key “2”, this completes the de-registration process. Upon successful de-

registration, the handset display will show "Please register".

**Notes:**

1. The base station has a 30 second registration timeout starting from pressing the PAGE button. The handset has a 6 second registration timeout starting from the registration or de-registration option has been selected. The base station and handset will automatically exit registration mode after timeout.
2. Repeat registration or de-registration process if unsuccessful.

1. The handset can change group affiliations at any time.
2. The base station is not responsible for group assignments. Consequently, it cannot de-subscribe a handset from a group.
3. When an intercom caller enters a group ID, all handsets subscribed to this group will ring. The first handset to answer will establish a link with the caller. Afterward, it is a one-to-one call, not a one-to-many call.

**Handset Group Subscription**

1. Up to nine handset groups (91-99) can be defined and handsets can decide which group(s) they want to be in.
2. For example, Group 1 represents the Customer Service Group, Group 2 represents the Sales Group, and Group 3 is the Marketing Group. Suppose that Handset 11 wants to receive incoming rings for all Sales and Marketing related calls. Then handset 11 will need to "subscribe" to Group 2 and Group 3.
3. Group Selections:
  - a. Press handset **MENU**-4 to enter the Call Settings menu
  - b. Press number "2", handset enters group setting menu.
  - c. Press **OPTION** soft key and followed by "1" key to subscribe the group ("9 #", #:1~9). Enter 1~9.
  - d. Repeat for all desired groups.

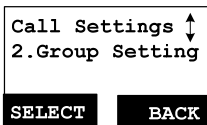
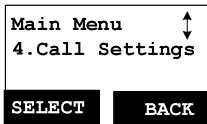

- e. Delete group selections by pressing **OPTION** soft key and followed by "2" to Unsubscribe the group.



**Notes:**

**Call Transfer**

While a telephone call is in progress, you can transfer it between different handsets.

**Direct transfer**

1. Press **GID HOLD** key to put the call on hold.
2. Press **XFER** (Right) soft key, followed by the destination handset ID, then the held call will be transferred directly.

After the call transferred to destination handset, the original handset will go back to standby mode automatically.

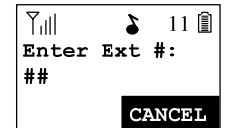
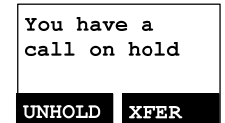
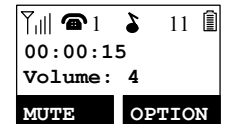

**Indirect transfer**

If you want to talk to the destination handset before the call transferred, you can follow with below method:

1. During the call, press **INT** key, followed by entering the destination handset ID.
2. Press the **FLASH** or **INT** of the destination handset to answer the intercom call, you can now talk to the destination handset. After the talking, press **END** to end the intercom call, then the destination handset is able to pick up the incoming call automatically.

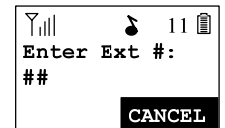
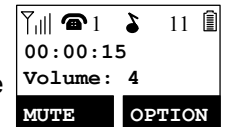

After the call transferred to destination handset, the original handset will go back to standby mode

automatically.

**Notes:** If the destination handset does not answer after handset paging or transferring timeout, the call is routed back to the originating handset.

## Phonebook Operations

1. You can store up to 50 entries in the phonebook. Each entry can contain a phone number or handset ID (up to 26 digits) and a name (up to 16 characters).

2. To access the phonebook, press **MENU** (Right) soft key, followed by **2**; or press  scrolling key while the handset is in standby mode.

Main Menu  
2.PhoneBook

↑ ↓

**SELECT** **BACK**

3. To add a new entry:
  - a. Press **ADD** (Left) soft key.
  - b. Enter the name when LCD prompts "Name?" Use **DELETE** (Right) soft key to delete the last digit entered. When completed, press **SAVE** (Left) soft key to save.

Joe  
033289289

↑ ↓

**ADD** **OPTION**

Name?

— Caps = \*

**SAVE** **DELETE**

- c. You will then be prompted to enter a number for the name just entered.  
Re: Up to 26 digits can be entered as the number.
- d. After entering the number, press the **SAVE** (Left) soft key to save this entry into phonebook.

Number?







—

**SAVE** **DELETE**

- e. Enter a phonebook entry without a name, the all records without name will be placed on top of the phonebook list.
- f. To enter the name, press the corresponding keypad number one or more times according to the order of the character on the key.



See table below for a list of available characters and their orders. For example, press **2** once for the character "A", twice for "B", etc.

### Notes:



1. When enter a phone number, the cursor automatically advances to the next digit field. Use  or  scrolling key to move the cursor backward or forward to insert or delete (the digit above the cursor, or left of the cursor if cursor is on the right of the last digit).
2. When entering a name, the cursor automatically advances to the next character field if you press a different key for the next character. If you need to enter consecutive characters from the same key, you can wait for the cursor to advance or use  or  scrolling key to move the cursor backward or forward manually. Also use  or  to move the cursor to insert (to the left of the cursor) or delete (the character above the cursor, or left of the cursor if cursor is on the right of the last character).
3. By default, all letters are entered in the upper case. Use the \* key to toggle between upper and lower cases.
4. A "Pause" entry represents a 1 second delay in dialing the following digits, which is useful when calling a sequence of segmented numbers (e.g., access code, credit card number, auto-attendant entries, etc.) Pause is entered by pressing the # key twice (LCD displays P). Entering pause twice (PP) will result in 2 seconds pause in the dialing.

### 5. Character Table:

Key	Characters and Orders
1	' + , . * ( ) & 1
2	A B C 2
3	D E F 3
4	G H I 4
5	J K L 5
6	M N O 6
7	P Q R S 7
8	T U V 8
9	W X Y Z 9
0	0
*	Caps – when in character editing. * – when in number editing.
#	Space & # – when in character editing # & P (Pause) – when in number editing



4. The entries are alphabetically sorted and stored as a list in an ascending order (A to Z) from the top of the list.
5. The first line of LCD display shows name and the 2<sup>nd</sup> line shows the phone number. If the phone number is longer than 16 digits, press **OPTION** (Right) soft key and select Option 3 “View Number” to view the complete number.
6. To search for a record:
  - a. Use  scrolling key to enter the Phone Book mode.
  - b. Press a key that corresponds to the first character of the name you are looking for.
  - c. For example, you are looking for “EnGenius”, and then press the number **3** once.
  - d. Use  or  scrolling key to locate the exact record you are looking for.

7. To erase phonebook:

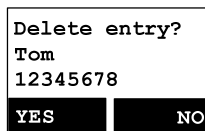
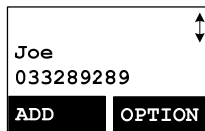
- a. Use  or  scrolling key or the alphabetical search method to locate the record to be erased or edited.
- b. Press **OPTION** (Right) soft key to enter option menu.
- c. Press **1** to erase the designated phone entry.
- d. LCD shown “Delete entry?” Press **YES** (Left) soft key to confirm your change.



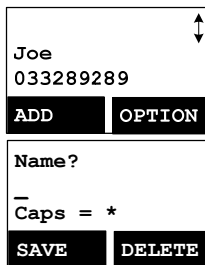

8. To edit phonebook:

- a. Use  or  scrolling key or the alphabetical search method to locate the record to be erased or edited.
- b. Press **OPTION** (Right) soft key to enter option menu.
- c. Press **2** to edit the designated phone entry.





9. Dial from display:

- a. Press  or  to dial the phone number or Handset ID displayed.

10. To transfer phonebook:

To transfer phonebook, both parties have to enter the phonebook transfer mode firstly by following below:

- a. Press **OPTION** right soft key follow by **5** or  or  scrolling key to transfer when handset in phonebook mode.
- b. For phone sending party, press **1** to enter sending mode.
  - i. Either press **TX ALL**(left softkey) to transfer all phonebook entries to another handset(s).
  - ii. Or press **TX ONE**(right softkey) to transfer one entry to another handset(s).
  - iii. Press 2-digit handset ID or group ID, then select all phonebook entries or one entry to be transferred.  
Re : “00” means all handsets
  - iv. During phonebook transferring, LCD shows “Sending” and 2-digit countdown on the LCD to indicate the phonebook numbers which are waiting for sending.
- c. For phonebook receiving party, press **2** to enter receiving mode.
  - i. When entering the receiving mode, LCD shows “Ready”.
  - ii. Start to receive phonebook, LCD shows “Get phonebook from Ext. # : xx”.
  - iii. A beep emitted when receiving each phonebook.
  - iv. When the phonebook receiving, 2-digit countdown on the LCD to indicate the phonebook numbers which are waiting for receiving.

Re: The phonebook transfer through the wireless interface, it may partially miss transmission by interference.

### Call Barring

1. Block the users from dialing the long distance calls or international calls. And also block the incoming call from outside line or other registered handset.  
You need the password to enter the setting. The default password of handset is “0000”.

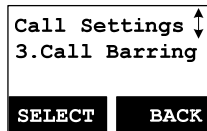

2. Press **MENU**-4-3 to enter Call Barring. Enter the password of handset, followed by **OK** (Left) soft key

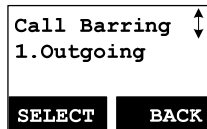

### Block Outgoing Call

1. Press **SELECT** left soft key to select to block "Outgoing" and confirm your selection.



2. Use  or  scrolling key to switch between On and Off of this setting. Press **SELECT** left soft key to confirm your selection.  
Re : The default of Call Barring is "Off".

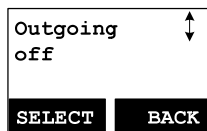

3. To add the Call Barring code

- a. Once turn on the Call Barring feature, you can key in the "Call Barring" code. Press **ADD** (Left) soft key then start entering the Call Barring code After the number entered, press **SAVE** (Left) soft key to save it.

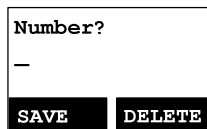

- (1) Up to 5 digits can be edit to be Call Barring code. For example, if you want to block all call dialing to Manhattan, NY area, you can enter 1212 as the Call Barring code.
- (2) If you base station is adjunct to a PBX system, please also include that specific number to retrieve the PSTN tone.

- b. Press **OPTION** right soft key to delete or edit the Call Barring codes.
- c. Up to 5 sets of Call Barring codes can be programmed.

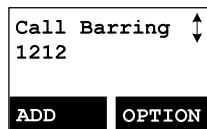



- d. If wants to block all outgoing calls, enter "\* \* \* \* \*" 5 "\*" keys followed by, press **SAVE** (Left) soft key to save it, all outgoing calls will be restricted.

### Block Incoming Call

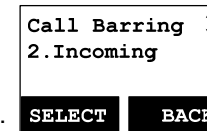
1. Press **SELECT** left soft key to confirm your selection for "Incoming".



Use  or  scrolling key to select blocking item.

- a. Press **SELECT** left soft key to confirm your selection for receiving or blocking broadcasting.

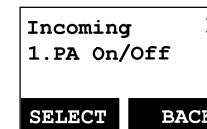

Press **CHANGE** left soft key to switch between On and Off of this setting.

Re: "On" means to be able to receive broadcast from other handsets or base station. "Off" means to restrict the broadcast from other handsets or base station.

- b. Press **SELECT** left soft key to confirm your selection for receiving or blocking line call.

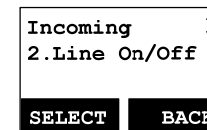

Press **CHANGE** left soft key to switch between On and Off of this setting.

Re: "On" means to be able to receive calls from outside line; "Off" means to restrict calls from outside line .

- c. Press **SELECT** left soft key to confirm your selection for receiving or blocking intercom call.

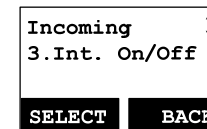

Press **CHANGE** left soft key to switch between On and Off of this setting.

Re: "On" means to be able to receive intercom calls from other handsets or base station; "Off" means to restrict intercom calls from other handset or base station.

## Programmable Feature Call

1. If EP802 base station is installed behind a PBX system, it is feasible to pre-program some feature call along with the PBX's feature code into the system.
2. Up to 10 most frequently used feature call codes can be pre-programmed.
3. Name and enter feature call codes:

- a. Press **MENU** (Right) soft key while the handset is in the standby mode.
- b. Press "4", followed by "4" to enter the "Feature Call" menu.
- c. Press **ADD** (Left) soft key to add a new entry of feature call.
- d. Key in the name of feature call, like editing a phonebook entry, i.e. "PBX Transfer". Press **SAVE** (Left) soft key to confirm.
- e. Key in the feature call code of the correspondence PBX feature i.e. F\*70. Press **SAVE** (Left) soft key to confirm. Re: "F" represent the Flash signal.

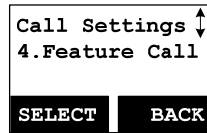

- f. The 1<sup>st</sup> feature call and correspondence feature call code you entered will appear on the LCD screen.

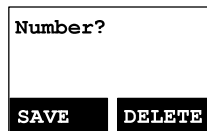

- g. Press **OPTION** (Right) soft key to delete or edit the feature call you programmed into the system.
- h. Repeat the same operations to program 2<sup>nd</sup> and even more feature call that you will use frequently.



4. Using pre-programmed feature call during the call.

- a. Press **OPTION** (Right) soft key while the handset is in the talk mode.
- b. Press the correspondence number of the feature call which you want to perform i.e. press "0" to perform the "PBX Transfer".

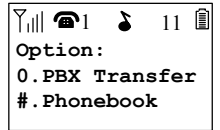

### Notes:

1. This feature call would be useful if the EP802 base station is adjunct to a PBX system,
2. if you have not pre-programmed any feature call into the system, only "#.Phonebook" in the **OPTION** menu.
3. The EP802's programmable feature call may not function with all PBX or Key phone systems due to the diversity of various proprietary systems.



## Caller ID

1. Contact with your local phone company to subscribe to this feature. The phone system receives and displays Caller ID information transmitted by your local phone company. This information may include the calling phone number, name, date and time. This unit can store up to 50 calls of caller ID information.
2. The display will show the date and time of call on the first line, followed by the name on the second line, and the phone number on the third line. An unread record will have a "NEW" at the end of the first line of display.
3. When viewing a call record, the number can be dialed, stored to the phonebook or deleted.

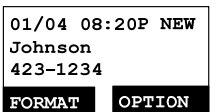

### View Call Log

1. To view the call log, press **CID HOLD** to enter the Call Log. Press **▲** or **▼** key to scroll through the numbers and names when available.





2. Press **OPTION** right soft key, you can  or  key to choose save, delete, clear all.

a. Save call log:

(1) Press **SELECT** right soft key, you can use  or  key to scrol the name, and press **DELETE** to edit the name. Then press **SAVE** left soft key to save the name.

Option:  
Save

**SELECT** **BACK**

(2) Use  or  key to scrol the number, and press **DELETE** to edit the number. Then press **SAVE** left soft key to save the number.

Name?  
Johnson\_  
Cap = \*

**SAVE** **DELETE**

(3) After above process, the call log saved into phonebook.

Number?  
4231234\_

**SAVE** **DELETE**

b. Delete call log:

(1) Press **SELECT** right soft key followed by **YES** left soft key to confirm deleting.

Option:  
Delete

**SELECT** **BACK**



c. Clear All:

(1) Press **SELECT** right soft key followed by **YES** left soft key to confirm clearing all caller ID records.

Option:  
Clear all

**SELECT** **BACK**

### Call a Caller ID

1. Press  key, use  or  key to scrol the call log.

2. When display a caller ID, Press  or  to dial this number.

### Multi-Base Setting

“Multi-Base” setting allows expanding coverage or lining capacity. When adding 2<sup>nd</sup>, 3<sup>rd</sup> or 4<sup>th</sup> base station, using one of the handsets which registered to the 1<sup>st</sup> base station (i.e. the handset with ID 11), followed by below processes :

1. Press **MENU** right soft key followed by “7” to enter the registration mode.

Registration  
3.Multi-Base

**SELECT** **BACK**

2. Press & hold the base station PAGE button for thress seconds, the base station will emit the prompt sound (also the base In Use LED is flashing).

Set Base  
BS #1

**SELECT** **BACK**

3. Press digit “3” of handset to enter the Multi-Base setting.

4. Select BS # 1

5. Repeat above step 1 ~ 4 to continuously add the 2<sup>nd</sup>, 3<sup>rd</sup> or 4<sup>th</sup> base station.

Re : The base ID for 1<sup>st</sup> base station is “10”, for 2<sup>nd</sup> base station is “20”, for 3<sup>rd</sup> base station is “30”, for 4<sup>th</sup> base station is “40”.

#### Notes:

1. When initial setting the “Multi-Base”, you have to select the BS #1 first, then followed the above steps to select 2<sup>nd</sup>, 3<sup>rd</sup> or 4<sup>th</sup> base.
2. For synchronization mechanism, all handsets must be register again before start using multi-base scenario. i.e. the initial handset ID with 1x must register to BS1, and the rest handsets must be registered to 2<sup>nd</sup>, 3<sup>rd</sup> or 4<sup>th</sup> base station respectively.
3. After all above processes, the “Multi-Base” is complete then.



## Call Manager

“Call Manager” feature allows two options :

1. One is the handset to be set to receive incoming calls or make outgoing calls (2-way intercom, broadcast and transferred call are allowed). The option is selectable by base station 1 to base station 4.  
Re: “Call Manager” item will be hidden if Multi-Base function is disabled.
2. The other option is the handset to be set to access to available bases automatically or manually.

For 1<sup>st</sup> option (Subscribe BS) :

1. Press **MENU** right soft key followed by **4** to enter the Call Settings mode.  
Press “6” to select Call Manager.  
Re: “Call Manager” item available or selectable only if Multi-Base function is enabled.

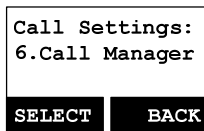

2. Press **1** to set Subscribe BS.  
Re : When entering the submenu of Subscribe BS, the LCD will show the available bases which already subscribed.



3. Press or key to select the desired base station (#1~4), press **CHANGE** left soft key to set the Subscribe BS ON/OFF.
4. If set the Subscribe BS ON, that means the handset is able to access the line of the desired base station, so the handset is able to make outgoing call or answer incoming call via the desired base station. On the contrary, if set the Subscribe BS OFF, then the handset can't access the line of the desired base station, so the handset isn't able to make outgoing call or answer incoming call via the desired base station.

For 2<sup>nd</sup> option (BS Selection) :

1. Press **MENU** right soft key followed by **4** to enter the Call Settings mode.  
Press “6” to select Call Manager.

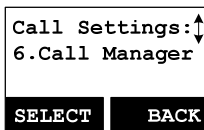

2. Press “2” to set BS Selection.  
Re : Default setting is “OFF”.

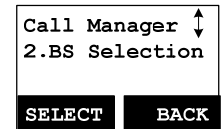

3. Press **CHANGE** left soft key to set the BS Selection ON/OFF.

Re : If BS Selection set “ON” , when pressing or key, the LCD will show the available bases (Lines), i.e. 1, 2, 3, 4. Press digit “1”, you can access to base 1 to get the line.

**Note : When single base, no “Call Manager” setting in “Call Settings”.**

## Visual Message Waiting Indicator (VMWI)

VMWI feature supported the FSK message which received from telephone line; It will activate a message icon of handset and flash the LED of base.

**Notes:**

1. A subscription to telephone company voice mail service is required.
2. If the handset still indicates the icon even after you have listened all messages, turn it off by pressing and holding “Caller ID” key on the handset.

## Adjust Handset Microphone Gain

In case you will use the handset in different workplace or environment, to perform better voice quality for the other end, you can adjust the handset microphone gain to suit for variable place.

- a. Press **MENU** right soft key while the handset is in the standby mode.
- b. Press “5” (Phone Settings), followed by “1” to enter the “Mic. Gain” menu.
- c. Use or key to scroll the “Standard”, “Medium” and “Low” options.
- d. If you are using the handset in quiet environment, like office or meeting room, the level of “Standard” is recommended.

If you are using the handset in a noisy environment, like factory or outdoor place, the level of “Medium” or “Low” is recommended.

## Adjust Headset Ring

When using headset, to avoid missing the call due to the ringer emitted from receiver of headset, you can change the ringer emitting from either handset speaker or receiver of headset.

- a. Press **MENU** right soft key while the handset is in the standby mode.
- b. Press “5” (Phone Settings), followed by “9” to enter the “Headset Ring” menu.
- c. Select “On”, the ringer will be emitted from the receiver of headset; If select “Off”, the ringer will be emitted from handset speaker.

## Baby Monitor

You can set any one handset as a “baby unit” to monitor the movement of baby or older person.

When enabling the baby monitor, the “baby unit” will automatically enter the monitoring mode via 2-way intercom.









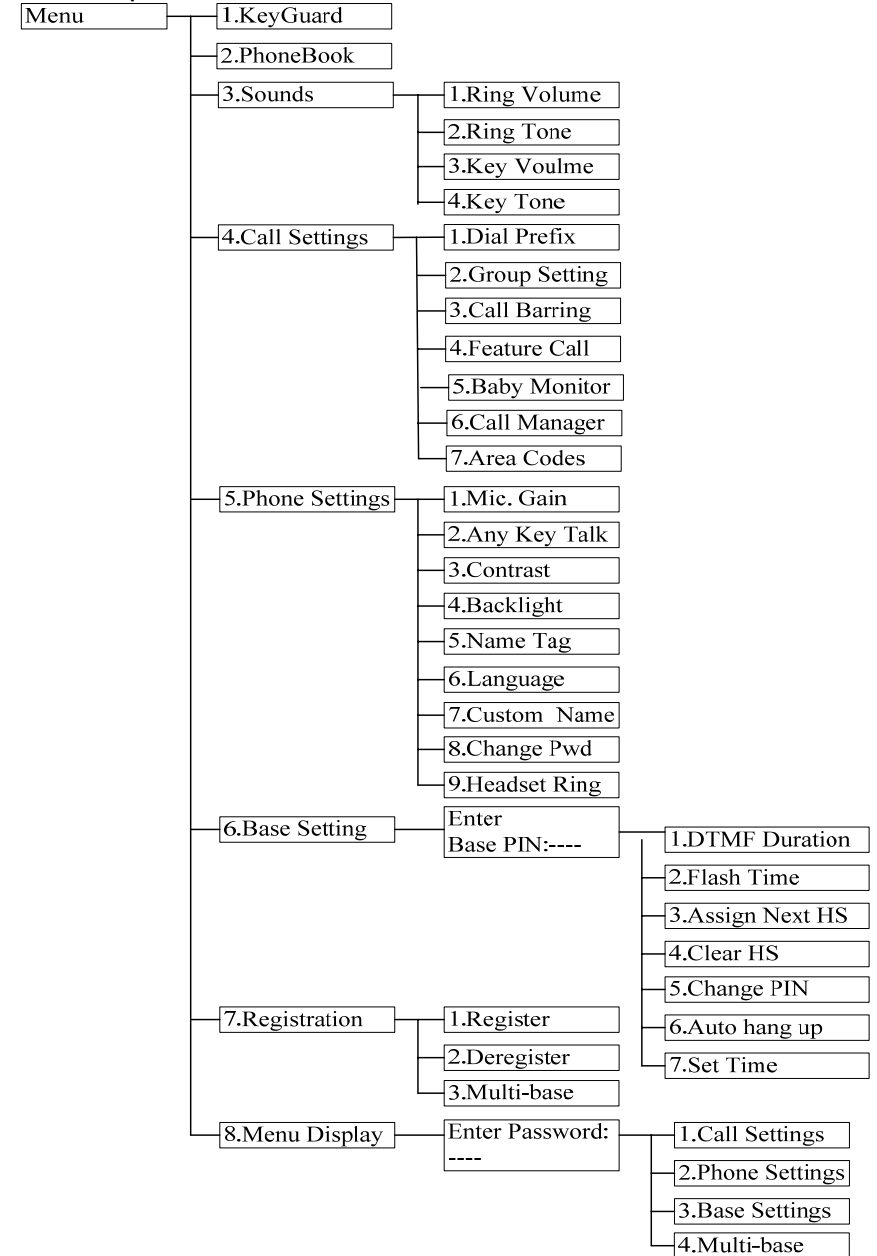

For example, if setting handset A as a “baby unit”, when making an intercom call from handset B, the handset A will automatically enter monitoring mode without ringing; Also you can hear the all movements around the handset A via the handset B.



- a. Press **MENU** right soft key while the handset is in the standby mode.
- b. Press “4” (Call Settings), followed by “5” to enter the “Baby Monitor” menu.
- c. Press “CHANGE” to switch ON or OFF (default is OFF).









Re: To avoid any disturbance, during the monitoring, the dedicated handset will not answer any incoming call, except the intercom.



## Menu Operations



1. Press **MENU** right soft key to enter menu mode while the phone is in standby mode.  
 Re: You can either press  or , followed by **SELECT** left soft key to confirm the selected menu. Or Press the digit directly to confirm the selected menu. For example, press **MENU** right soft key followed by **4** and **1** to select the Ring Volume.
2. Press **1** to select KeyGuard (see Key Guard operation on page 34).
3. Press **2** to add, delete, edit, view and edit the phonebook (see Phonebook instruction on page 39).
4. Press **3** to set Sounds settings:
  - a. Press **1** to select Ring Volume:  
 Two options for ring volume: Line (for incoming call) and Intercom (for intercom call). Set each option respectively.  
 When setting each option, use  or  to scroll through 6 options: "Off", "Low", "Medium", "High", "Vibrate" and "Vibrate & High". Press **SELECT** left soft key to save selection. Default = Medium.
  - b. Press **2** to select Ring Tone:  
 Two options for ring tone: Line (ring tone for incoming call) and Intercom (ringer for intercom call). Set each option respectively.  
 Use the  or  to scroll through 8 ringers, press **SELECT** left soft key to save selection. Default = 1.
  - c. Press **3** to select Key Volume when a key is pressed:  
 Use  or  to scroll through 4 options: Off, Low, Medium, and High. Press **SELECT** left soft key to save selection. Default = Medium.
  - d. Press **4** to select Key Tone:  
 Use the  or  to scroll through 4 options: 1, 2, 3 and 4. Press **SELECT** left soft key to save selection. Default = 1.

5. Press **4** to set Call Settings:
  - a. Press **1** to set Dial Prefix:
    - (1) Press  or  to turn on or off the dial prefix feature. Default = Off.
    - (2) If "On" is selected, the handset is prompted to enter the prefix number, up to 14 digits can be entered.
    - (3) Use **Delete** right soft key to edit prefix number.
    - (4) Press **SAVE** left soft key to confirm the selection.
    - (5) When this feature is turned on, the LCD will prompt the user "Dial Prefix? Yes or No" on each outgoing phone call from call logs, phonebook, and dial-and-send dialing, the current prefix is also displayed.  
 Re: the prefix number will be added automatically in front of the dialed number if press **YES** left soft key.
    - (6) This feature is useful for access code, calling card, and credit card calls, etc.
  - b. Press **2** to Group Select: see Handset Group Subscription on page 37.
  - c. Press **3** to set Call Barring: see Call Barring operation on Page 42.
  - d. Press **4** to set Feature Call: see Feature Call operation on Page 45.
  - e. Press **5** to set Baby Monitor: see Baby Monitor operation on Page 51.
  - f. Press **6** to set Call Manager: see Call Manager operation on Page 49.
  - g. Press **7** to set Area Code:  
 The area code setting allow calls within local and regional area codes to be dialed without prefix.
    - (1) Set Local Area Code :  
 Press **MENU-4-7-1** to set the LAC. Enter the local area code (3-digit) then press **SAVE** left soft key to confirm selection.
    - (2) Set Country Area Code :  
 Press **MENU-4-7-2** to set the country code. Enter the code (3-digit) then press **SAVE** left soft key to confirm selection.
6. Press **5** to set Phone Settings:
  - a. Press **1** to set Mic Gain: See Mic Gain operation on Page 50.

- b. Press **2** to set Any Key TALK:  
Use **CHANGE** left soft key to select and confirm "On" or "Off".  
Default is "Off".  
Re: When set "on", press any key (except  and **SILENT** key) to answer the incoming call.
- c. Press **3** to set LCD Contrast:  
(1) Use  or  to scroll through option 1~8. Default is 6.  
(2) Press **SAVE** left soft key to confirm selection.
- d. Press **4** to set LCD Backlight:  
(1) Use  or  to scroll through option 1~3 (1.8 seconds 2.On 3.Off ). Default is "8 seconds".  
(2) Press **SAVE** left soft key to confirm selection.
- e. Press **5** to set Name Tag:  
(1) Use **CHANGE** left soft key to select and confirm "On" or "Off".  
Default is "Off".  
(2) Press **SAVE** left soft key to confirm selection.  
Re: When Set "On", the handset match the caller ID with the phone book entries; once matched, the LCD screen will display the name or nickname instead of pure caller ID info (needs Call Waiting with Caller ID service from local telephone company)
- f. Press **6** to set Language:  
(1) Use  or  to scroll through option (English, Spanish, French, Italian, German, Dutch, Polish, Czech, Hungary, Romanian, Turkish).  
Default is "English".  
(2) Press **SAVE** (Left) soft key to confirm selection.
- g. Press **7** to set Custom Name:  
(1) Enter characters using the Character Table and method discussed in the Phonebook section.  
(2) Use  or  to move the cursor backward or forward to insert (to the left of the cursor) or delete (the character above the cursor, or left of the cursor if cursor is on the right of the last character).

- (3) Press **SAVE** (Left) soft key to confirm setting.  
Re: Once entering the custom name, the greeting of LCD in standby mode will be changed as the entering.  
Default greeting is "EP802".
- h. Press **8** to Change Password:  
(1) Enter original password (4 digits) of handset then press **OK** left soft key when enter this menu.  
(2) Enter new password (4 digits) then press **SAVE** left soft key to confirm new password.
- i. Press **9** to set Headset Ring: See Headset Ring operation on Page 51.
7. Press **6** to set Base Settings:  
When enter this menu, you must enter Base PIN code first (4 digits).  
Re: The PIN code is for Base Settings. Default is "0000".
- a. Press **1** to set DTMF Duration.  
(1) Enter the DTMF duration (90~200ms), press **OK** left soft key to confirm the setting. Default is 100ms.  
Re: Please check with your dealer before you change it. If the duration not matches with PSTN or PBX setting, it may operate faultily.
- b. Press **2** select flash key timing. Default is 600ms.  
(1) Use  or  to scroll through option 1~9 (100~900ms). Or press digit key (1~9) directly.  
(2) Press **SELECT** left soft key to confirm selection.  
Re: The default value (600 ms) works in most areas. Changing this setting may cause Flash key not working. Change only when you are certain of the new value would work.
- c. Press **3** to set Assign Next HS  
(1) Enter 2-digit handset ID followed by pressing **OK** left soft key.  
(2) When register a new handset, the base will assign the specific handset ID which assigned in advance to the new handset.
- d. Press **4** to set Clear HS  
(1) Enter 2-digit handset ID followed by pressing **OK** left soft key.  
(2) The base will erase the handset ID from system.
- e. Press **5** to Change PIN:  
(1) Enter the new Base PIN followed by **OK** left soft key.  
Re: Default Base PIN is "0000".
- f. Press **6** to set Auto Hang Up:

(1) Use **CHANGE** left soft key to select and confirm on or off. The Re: When setting “on”, the EP802 will automatically hang up if the far end caller hung up already. However, this function depends on if there is “dial tone or busy tone” signal sent out by PBX or PSTN, after the call hung up.

g. Press **7** to Set Time to support DTMF Caller ID:

(1) Use **SAVE** left soft key to select and confirm the Date and Time you have set (see Set Time operation on page 20).

8. Press **7** to register, de-register handset and set Multi-Base: see Handset Registration operation on Page 36, and Multi-base Setting on Page 48.

9. Press **8** to set Menu Display:

To avoid mis-setup of Call Settings (MENU-4), Phone Settings (MENU-5) and Base Settings (MENU-6), you can hide these menus, so that other handset users won't have chance to mis-setup these settings.

Re: When entering the Menu Display, you have to enter password first.

a. Press **1** to set hiding/un-hiding of the Call Settings menu.

(1) Use **CHANGE** left soft key to select and confirm on or off.

b. Press **2** to set hiding/un-hiding of the Phone Settings menu.

(1) Use **CHANGE** left soft key to select and confirm on or off.

c. Press **3** to set hiding/un-hiding of the Base Settings menu.

(1) Use **CHANGE** left soft key to select and confirm on or off.

d. Press **4** to set hiding/un-hiding of the Multi-base Settings menu.

(1) Use **CHANGE** left soft key to select and confirm on or off.

Re: Select “On” means the menu will be displayed on screen. Select “Off” means the menu will be hidden.

## Index

- 2

2-Way Intercom, 14, 29

- A

Adjusting Receiver (Earpiece) Voice Volume, 33

Adjusting Handset Speakerphone Voice Volume, 33

Adjust Handset Microphone Gain, 50

Adjust Headset Ring, 51

Area Code, 19, 54

- B

Base ID, 48

Base Illustration, 21

Base Operation, 27

Base PIN, 18, 19, 20

Base Station, 5, 6, 9, 10, 14, 15, 20, 22, 25, 26, 27, 28, 30, 36, 43

Base Station Features, 22

Base Station Installation, 25

Battery, 5, 7, 10, 24, 26, 27, 35

Battery Recharge and Replacement, 35

Battery Safety Instructions, 7

Battery Strength, 13

Block Incoming Call, 43

Block Outgoing Call, 43

Broadcast, 14, 16, 18, 31, 44, 49

Broadcasting a Group of Handsets, 30

Broadcasting all Handsets, 30

Broadcasting an Individual Handset, 31

BS Selection, 49

- C

Call Barring, 16, 18, 42, 43, 54

Call Log, 16, 17, 46, 47

Call Timer, 17

Call Transfer, 33, 37

Call Hold, 17

Caller ID, 15, 20, 31, 32, 46, 47, 50, 55, 56

Call in-progress, 13

Call Manager, 49, 50, 54

Call Settings, 16, 18, 20, 37, 49, 50, 51, 54, 57

Call Waiting, 14, 15

Call Waiting with Caller ID, 15, 55

Cardiac Pacemaker, 4  
Change PIN, 18, 19, 56  
Charger Features, 24  
Charger Illustration, 23

- D

De-registration, 36  
DND, 15  
Do Not Disturb (Silent Ring), 15, 34  
DTMF Tone, 18  
DTMF Duration, 18, 56

- E

Electric Shock, 4, 5, 6  
Emergency, 4  
Equipment Checklist, 10

- F

Flash, 14, 19, 36, 45, 48, 50, 56  
Feature Call, 17, 45, 54

- G

General Safety Instructions, 4  
Group ID, 15, 30, 38, 42  
Group Setting, 18, 37  
Group Selections, 37, 54

- H

Handset and Charger Installation, 26  
Handset Charging Slot, 24  
Handset Features, 13, 15  
Handset Group Subscription, 37, 54  
Handset ID, 13, 15, 17, 19, 22, 27, 30, 31, 32, 36, 38, 39, 42, 48, 56  
Handset Registration, 36, 57  
Handset to Handset Call, 30  
Hearing Aid, 4

- I

IDLE Mode, 17, 27, 35

- K

Key Guard, 34, 53  
Key Tone, 17, 53  
Key Volume, 53

- L

Line Jack, 22  
Lithium-Ion (Li-Ion), 7, 10  
Line Reversal, 56

- M

Making a Broadcast, 30  
Making a Telephone Call, 29  
Making an 2-Way/ Intercom Call, 29  
Memory, 27  
Menu Display, 18, 57  
Menu Mode, 27, 53  
Multiple Handsets Registration, 15  
Multi-Base Setting, 18, 48, 57  
Mute, 17, 33

- N

Name Tagging, 15, 55

- O

Outdoor Antenna, 10, 22

- P

Phonebook, 14, 16, 17, 39, 45, 46, 47, 53, 55  
Phone Settings, 18, 20, 50, 51, 54, 57  
Placing a Call On Hold, 33  
Power Outage, 5, 9, 25, 26  
Product Safety Instructions, 5  
Programmable Flash, 19  
Programmable feature call, 17, 45, 46

- R

Receiving a Telephone Call, 31  
Receiving an Intercom Call, 32  
Redial, 16, 31  
REG, 22, 37, 48  
Registration Key, 22  
Registration Mode, 22, 27, 36, 48  
Regulatory Information, 8  
REN, 8  
Reset Button, 22  
Ringer, 14, 15, 20, 31, 32, 34, 51, 53

Ringer Volume, 14, 15  
 RSSI, 13

- S
- Safety Instructions, 4
- Set Time, 20
- SILENT, 15, 32, 34
- Spare Battery, 10
- Speed Dial, 29
- Speakerphone, 14, 30, 31, 33, 48
- Subscribe BS, 49

- T
- Talk Mode, 14, 27, 46
- Talk/Flash, 14
- Technical Specifications, 62
- Transformer, 25, 26
- Two-Digit Address Index, 13

- V
- Vibrator, 15
- View Call log, 46
- Visual Message Waiting Indicator, 50

- W
- Warning Message, 24

## Technical Specifications

Electrical Specifications	Base Station	Portable Handset
Frequency	863-865 MHz	863-865 MHz
RF Output Power	Peak: 8 dBm	Peak: 7 dBm
	Average: 5 dBm	Average: 5 dBm
Channel Spacing	50 kHz	50 kHz
Number of Channels	38	38
Modulation	GMSK	GMSK
TDD Frame Length	10 ms	10 ms
Number of Slots/Frame	2	2
Receiver Sensitivity	<-116dBm (@ BER 10 <sup>-2</sup> )	<-116dBm (@ BER 10 <sup>-2</sup> )
Antenna Gain	2 dBi	Long: 2.5 dBi Short: 1.5 dBi
Antenna Connector	TNC	Proprietary
Telephone Interface	RJ11 x 2	NA
Channel Coding	½ rateConvolutional + CRC	½ rateConvolutional + CRC
Transmission Data Rate	42.667kbps	42.667kbps
Speech Coding	8 kbps G.729A	8 kbps G.729A
User Data Rate	32kbps duplex	32kbps duplex
Duplex	Time Division Duplex (TDD)	Time Division Duplex (TDD)
Multiple Access	FDMA	FDMA
Number of System ID	65,536	65,536
Ring Signal	20-50 Hz, 12-90 Vrms	NA
Flash Time	100-900 ms programmable	NA
Power Source	AC/DC 12V/1A Adapter	3.7 V/1100mAh Li-Ion Battery
Charger Current	NA	550mA
		(550/850 mA for desktop charger)
Charge Time	NA	3hours
Regulation Compliance	EN 301 357-2 (RF)	EN 301 357-2 (RF)
	EN 301 489 (EMC)	EN 301 489 (EMC)
	EN 60950 (Safety)	EN 60950 (Safety)
		EN 50371 (RF safety)
Operating Temperature	0 – 50 °C	-10 – 60 °C
Charging Temperature	NA	0 – 50 °C

### Notes:

1. NA = Not Applicable.
2. The manufacturer reserves the right to change designs and specifications without notice.