

Panasonic

Digital Proprietary Telephone

Quick Reference Guide

Model No. KX-T7665

Important Information

When using the KX-T7665, keep the following conditions in mind.

- If there is any problem, unplug the extension line and connect a known working phone. If the known working phone operates properly, have the defective phone repaired by a specified Panasonic Factory Service Centre. If the known working phone does not operate properly, check the KX-TDA series Business Telephone Systems and the internal extension wiring.
- Keep the unit away from heating appliances and electrical noise generating devices such as fluorescent lamps, motors and televisions. These noise sources can interfere with the performance of the unit.
- This unit should be kept free of dust, moisture, high temperature (more than 40 °C) and vibration, and should not be exposed to direct sunlight.
- Do not use benzene, thinner, or the like, or any abrasive powder to clean the cabinet. Wipe it with a soft cloth.
- Do not use any handset other than a Panasonic handset.
- Do not disassemble this product. Dangerous electrical shock could result. The unit must only be disassembled and repaired by qualified service technicians.
- When a failure occurs which exposes any internal parts, disconnect the telephone line cord immediately and return this unit to service centre.
- Never attempt to insert wires, pins, etc. into the vents or other holes of this unit.
- This unit is designed to be installed under controlled conditions of ambient temperature and a relative humidity.
- Avoid installing the unit in damp or humid environments, such as bathrooms or swimming pools.
- 999 or 112 can be dialled on the product after accessing the CO line for the purpose of making outgoing calls to the BT emergency (999) and (112) services.
- This unit is designed to aid the visually handicapped to locate dial keys and buttons.
- This unit is capable of being used in conjunction with hearing aids fitted with inductive coil pick-ups. The handset should be held as for normal conversations. For operation the hearing aid should be set to its "T" position or as directed in the operating instructions for the hearing aid.



WARNING:

TO PREVENT FIRE OR SHOCK HAZARD, DO NOT EXPOSE THIS PRODUCT TO RAIN OR ANY TYPE OF MOISTURE.

THE HANDSET EARPIECE IS MAGNETISED AND MAY RETAIN SMALL FERROUS OBJECTS.

IMPORTANT NOTICE:

Under power failure conditions, this telephone may not operate. Please ensure that a separate telephone, not dependent on local power, is available for use in an emergency.

Note: In this manual, the suffix of each model number is omitted.

© 2003 Panasonic Communications Co., Ltd. All Rights Reserved.

Features List

- Outside (CO) Line button
 Off-hook
 On-hook
 Feature number
 Talk
 Incoming Call Distribution Group button
 Direct Station Selection button
 Confirmation Tone
 Ringback Tone





















Feature	Operation
Making Calls	
Calling	<p>To an extension ► ► </p> <p>To an outside party ► / ► ► </p>
Redial	► ►
Quick Dialling	► ►
One-touch Dialling	<p>To store ► ► ► ► ► </p> <p>To dial ► ► </p>
Operator Call	► ►
Personal Speed Dialling	<p>To store ► ► ► ► ► </p> <p>To dial ► ► ► ► </p>
System Speed Dialling	<p>To dial ► ► ► </p>
Doorphone Call	► ► ►
Automatic Callback Busy	<p>To set <i>While hearing a busy tone</i> </p> <p>To cancel ► </p> <p>To answer from an idle extension <i>While hearing a callback ring</i> </p> <p>To answer from an idle outside line <i>While hearing a callback ring</i> ► ► </p>
During a Conversation	
Call Hold	<p>To hold </p> <p>To retrieve a call at the holding extension ► / / ► </p> <p>To retrieve an outside call from another extension ► ► </p>

Features List



























Feature	Operation
During a Conversation	
Call Transfer	<p>TRANSFER C. Tone <input type="text" value="extension no."/> To an extension <input type="text" value="outside phone no."/> To an outside party </p>
Useful Features	
Off-Hook Monitor	<p>To set/cancel <i>During a conversation using the handset</i></p> <p> </p>
Call Park	<p>To set</p> <p>TRANSFER <input type="text" value="*"/> <input type="text" value="5"/> <input type="text" value="2"/> <input type="text" value="parking zone no. (2 digits)"/> Specified <input type="text" value="*"/> Auto</p>
	<p>To retrieve</p> <p> <input type="text" value="*"/> <input type="text" value="5"/> <input type="text" value="2"/> <input type="text" value="stored parking zone no. (2 digits)"/> </p>
Multiple Party Conversation	<p>To add other parties during a conversation</p> <p><input type="text" value="CONFERENCE button"/> assigned as a CONFERENCE button <input type="text" value="desired phone no."/> <input type="text" value="CONFERENCE button"/> assigned as a CONFERENCE button Talk to the new party. Talk with multiple parties.</p>
	<p>To leave a conference</p> <p><input type="text" value="CONFERENCE button"/> assigned as a CONFERENCE button </p>
Call Pickup	<p> <input type="text" value="DSS"/> <input type="text" value="*"/> <input type="text" value="4"/> <input type="text" value="1"/> <input type="text" value="extension no."/> Directed <input type="text" value="*"/> <input type="text" value="4"/> <input type="text" value="0"/> <input type="text" value="group no. (2 digits)"/> Group</p>
Sending a Call Waiting Tone	<p><i>While hearing a busy tone</i></p> <p><input type="text" value="1"/> Wait for an answer. </p>
Answering a Call Waiting	<p>To hold the current call then talk to the new party</p> <p><input type="text" value="HOLD"/> <input type="text" value="(CO)"/> / <input type="text" value="INTERCOM"/> * </p>

* Disregard this step if both parties are extensions.

Features List

Feature	Operation
Useful Features	
Paging	<p>To page</p>  → * 3 3 → paging group no. (2 digits) C. Tone  → Wait for an answer. C. Tone 
	<p>To answer</p>  → * 4 3 C. Tone 
	<p>To allow/deny a paged announcement</p>  → * 7 2 1 1 Deny * 7 2 1 0 Allow C. Tone 
Message Waiting	<p>Caller</p> <p>To leave a message waiting indication <i>When the called extension is busy or does not answer</i></p> MESSAGE C. Tone 
	<p>Called extension</p> <p>To call back</p>  → MESSAGE → 
Log-in/Log-out	 → * 7 3 6 1 For Log-in * 7 3 6 0 For Log-out → ICD Group extension no. Specified  C. Tone  All
Before Leaving Your Desk	
Setting Absent Message	<p>To set</p>  → * 7 5 0 → message no. (1-9) → parameter (if required) → # → 
	<p>To cancel</p>  → * 7 5 0 0 → 
Call Forwarding	 → * 7 1 → 0 Both Calls 1 Outside Calls 2 Intercom Calls
	<div style="border: 1px dashed black; padding: 10px;">  → 2 All calls 3 Busy 4 No answer 5 Busy/ No answer 0 Cancel</div> <div style="border: 1px solid black; padding: 10px; margin-top: 10px;"> extension no. OR CO line access no. → outside phone no. → # C. Tone  </div>

Features List

Feature	Operation													
Before Leaving Your Desk														
Extension Lock	To lock  ► * 7 7 1  													
	To unlock  ► * 7 7 0 ► extension PIN (max. 10 digits)  													
Setting the Telephone According to Your Needs														
Do Not Disturb	 ► * 7 1 ► <table border="1" style="display: inline-table; vertical-align: middle;"> <tr><td>0</td><td>Both Calls</td></tr> <tr><td>1</td><td>Outside Calls</td></tr> <tr><td>2</td><td>Intercom Calls</td></tr> </table> ► <table border="1" style="display: inline-table; vertical-align: middle;"> <tr><td>1</td><td>Set</td></tr> <tr><td>0</td><td>Cancel</td></tr> </table>  	0	Both Calls	1	Outside Calls	2	Intercom Calls	1	Set	0	Cancel			
0	Both Calls													
1	Outside Calls													
2	Intercom Calls													
1	Set													
0	Cancel													
Extension Setting Clear	 ► * 7 9 0  													
Timed Reminder	To set  ► * 7 6 0 1 ► <table border="1" style="display: inline-table; vertical-align: middle; border-style: dashed;"> <tr><td>12 H</td></tr> <tr><td>hour/minute (4 digits)</td></tr> <tr><td>► <table border="1"><tr><td>0</td><td>AM</td></tr><tr><td>1</td><td>PM</td></tr></table></td></tr> <tr><td>24 H</td></tr> <tr><td>hour/minute (4 digits)</td></tr> </table> ► <table border="1" style="display: inline-table; vertical-align: middle;"> <tr><td>0</td><td>once</td></tr> <tr><td>1</td><td>daily</td></tr> </table>  	12 H	hour/minute (4 digits)	► <table border="1"><tr><td>0</td><td>AM</td></tr><tr><td>1</td><td>PM</td></tr></table>	0	AM	1	PM	24 H	hour/minute (4 digits)	0	once	1	daily
	12 H													
hour/minute (4 digits)														
► <table border="1"><tr><td>0</td><td>AM</td></tr><tr><td>1</td><td>PM</td></tr></table>	0	AM	1	PM										
0	AM													
1	PM													
24 H														
hour/minute (4 digits)														
0	once													
1	daily													
	To cancel  ► * 7 6 0 0  													
	To stop or answer the ring back  / 													
Receiving Call Waiting	To set/cancel for intercom calls  ► * 7 3 1 ► <table border="1" style="display: inline-table; vertical-align: middle;"> <tr><td>0</td><td>No Call</td></tr> <tr><td>1</td><td>Tone</td></tr> <tr><td>3</td><td>Whisper OHCA</td></tr> </table>  	0	No Call	1	Tone	3	Whisper OHCA							
	0	No Call												
1	Tone													
3	Whisper OHCA													
	To set/cancel for outside calls  ► * 7 3 2 ► <table border="1" style="display: inline-table; vertical-align: middle;"> <tr><td>0</td><td>No tone</td></tr> <tr><td>1</td><td>Tone</td></tr> </table>  	0	No tone	1	Tone									
0	No tone													
1	Tone													



- For more details, refer to the Business Telephone System User Manual or consult your dealer.
- You can change the flexible CO buttons to the feature buttons.
- “Location of Controls” is shown on page 6.

Location of Controls

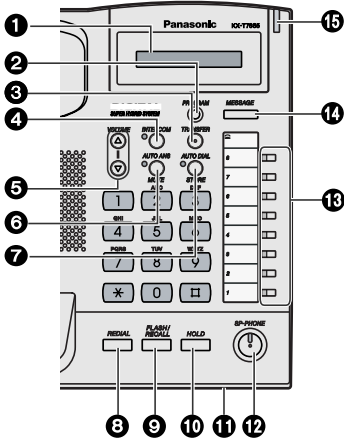

- ❶ **LCD (Liquid Crystal Display)**
- ❷ **PROGRAM:** Used to enter and exit the personal programming mode.
- ❸ **TRANSFER:** Used to transfer a call to another party.
- ❹ **INTERCOM:** Used to make or receive intercom calls.
- ❺ **VOLUME Control Button:** Used to adjust the volume.
- ❻ **AUTO ANS (Auto Answer)/MUTE:** Used to receive an incoming call in hands-free mode or mute the microphone/handset during a conversation.

- ❼ **AUTO DIAL/STORE:** Used for System/Personal Speed Dialling or storing programme changes.
- ❽ **REDIAL:** Used to redial the last dialled number.
- ❾ **FLASH/RECALL:** Used to disconnect the current call and make another call without hanging up.
- ❿ **HOLD:** Used to place a call on hold.
- ⓫ **Microphone:** Used for the hands-free conversation.
- ⓬ **SP-PHONE (Speakerphone):** Used for the hands-free operation.
- ⓭ **Flexible Outside (CO) Line Buttons:** Used to make or receive an outside call. Pressing this button seizes an idle outside line automatically. (Button assignment is required.) Also used as feature buttons. (Button assignment is required.)
- ⓮ **MESSAGE:** Used to leave a message waiting indication or call back the party who left the message waiting indication.
- ⓯ **Message/Ringer Lamp:** When you receive a call, the lamp flashes red. When someone has left you a message, the lamp stays on red.

◆◆ Setting

◆ Ringer volume

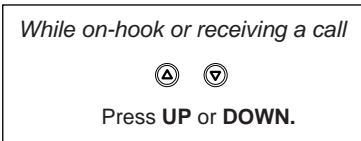

◆ LCD Contrast

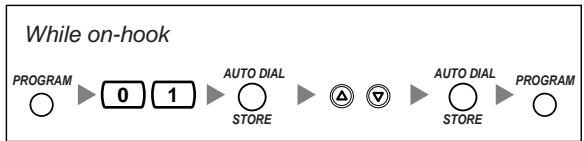

◆ Ring Tone

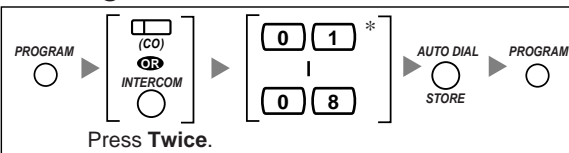

* The ring tone pattern of patterns 09 to 30 is the same as pattern 01.

Settings on the Programming Mode

To enter the programme mode		To exit	
PROGRAM ○		PROGRAM ○	
Operation			
Loop-CO (L-CO)	CO ► * ► AUTO DIAL STORE ○	FWD/DND - Both calls	CO ► 4 1 ► AUTO DIAL STORE ○
Single-CO (S-CO)	CO ► 0 CO line no. ► AUTO DIAL STORE ○	FWD/DND - Outside calls	CO ► 4 2 ► AUTO DIAL STORE ○
Direct Station Selection	CO ► 1 extension no. ► AUTO DIAL STORE ○	FWD/DND - Intercom calls	CO ► 4 3 ► AUTO DIAL STORE ○
One-touch Dialling	CO ► 2 desired no. ► AUTO DIAL STORE ○	Account	CO ► 4 8 ► AUTO DIAL STORE ○
Incoming Call Distribution Group (ICD Group)	CO ► 3 0 ► ICD Group no. ► AUTO DIAL STORE ○	Conference	CO ► 4 9 ► AUTO DIAL STORE ○
		Log in/Log-out	CO ► 5 5 ► AUTO DIAL STORE ○
Preferred Line Assignment-Outgoing	1 9 ► AUTO DIAL STORE ○	0 No line 1 An idle outside line 2 + CO button no. / CO A CO/ICD Group button 3 / INTERCOM ○ Intercom	AUTO DIAL STORE ○
Preferred Line Assignment-Incoming	2 0 ► AUTO DIAL STORE ○	0 No line 1 The longest ringing line 2 + CO button no. / CO An assigned outside button	AUTO DIAL STORE ○
Alternate Receiving-Ring/Voice	2 1 ► AUTO DIAL STORE ○	0 Ringing (Tone Call) 1 Directly (Voice Call) 2 Ring only	AUTO DIAL STORE ○
Call Waiting for Outside calls	3 0 ► AUTO DIAL STORE ○	0 No (No tone) / 1 Yes (Tone)	AUTO DIAL STORE ○
Call Waiting Selection	3 1 ► AUTO DIAL STORE ○	0 No Call / 1 Tone / 3 Whisper OHCA	AUTO DIAL STORE ○
Call Waiting Tone Type Selection	3 2 ► AUTO DIAL STORE ○	0 Tone 1 / 1 Tone 2	AUTO DIAL STORE ○
Extension PIN [Personal Identification Number] (PIN-max.10 digits)	9 0 ► AUTO DIAL STORE ○	To set an extension PIN [extension PIN ► AUTO DIAL STORE ○ ► same PIN] To change a stored extension PIN to new one [stored extension PIN ► new PIN ► AUTO DIAL STORE ○ ► same PIN]	AUTO DIAL STORE ○
Station Programming Data Default Set	# # ► AUTO DIAL STORE ○		AUTO DIAL STORE ○

Connection

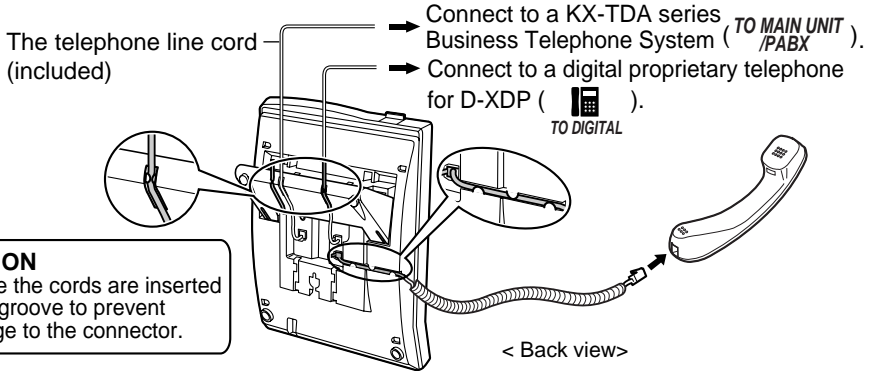

CAUTION

Ensure the cords are inserted in the groove to prevent damage to the connector.



- The availability of D-XDP function depends on the software version of the connected Business Telephone System. Consult your dealer for more details about D-XDP.

Wall Mounting

1 Pull down the handset hook until it locks, so the tab holds the handset.

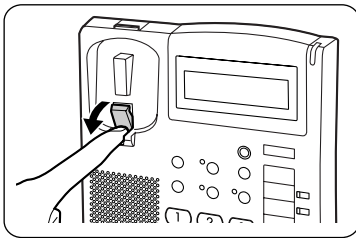

3 Mount the unit on the wall.

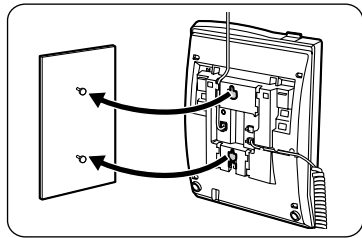

2 Remove the attached stand.

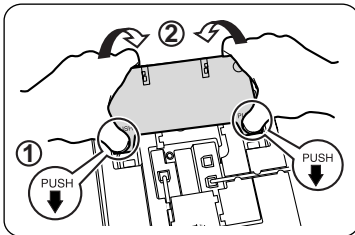

To temporarily place the handset down during a conversation, hook it over the top edge of the phone as shown.

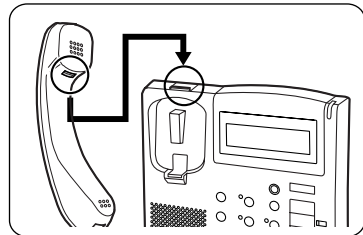

This product is intended to be connected to Panasonic KX-TDA series Business Telephone Systems only. We, Panasonic Communications Co., Ltd./Panasonic Communications Company (U.K.) Ltd., declare that this equipment is in compliance with the essential requirements and other relevant provisions of Directive 1999/5/EC.

If you want to get a copy of the original Declaration of Conformity of our products which relates to the R&TTE, please contact to our web address: <http://doc.panasonic-tc.de>

Panasonic Communications Company (U.K.) Ltd.

Pencarn Way, Duffryn, Newport, South Wales, NP10 8YE, United Kingdom

PSQX2972ZB KK0703TT0