

Robust Construction

- All Weather Protection
- Vandal Resistant
- Highly Reliable Operation
- Easy Install & Maintenance
- Industrial Temperature Range
- Web Server Configuration
- Full or Half Duplex Speech
- Single, Two or Three Button Auto-Dial
- Full Keypad Available
- Various Mounting Options



Network Interface

Network Interface	Features
VOIP	POE, SIP, Echo / Noise Cancelling, WEB interface, Self Testing, DHCP enabled, Calling Groups
GSM	Full / Half Duplex, Remote Configuration, SMS Reporting
Analogue	Full / Half Duplex, Line Powered (no additional power supply required)



The RA711 vandal & weather resistant telephones are based on a stainless steel faceplate and provide clear handsfree, loud-speaking operation. Manufactured to a high standard, these telephones offer increased resistance to vandalism, and ensure that the primary function of communications is always maintained.

The RA711 has been designed to meet the needs of clients who experience loss through vandalism. However, the telephone is extremely simple to install and offers a convenient solution to a range of telephone siting problems in all locations. The RA711 is available with various keypad configurations; including full keypad, single, two and three button auto-dial options.

The RA711 is easy to program and has a non-volatile memory to ensure stored numbers are not lost when line power is disconnected. Additionally, the entire range offers a timed or auto-clear down function, preventing an off-hook or 'hung' condition.



sales@daclimited.co.uk



Mounting options:

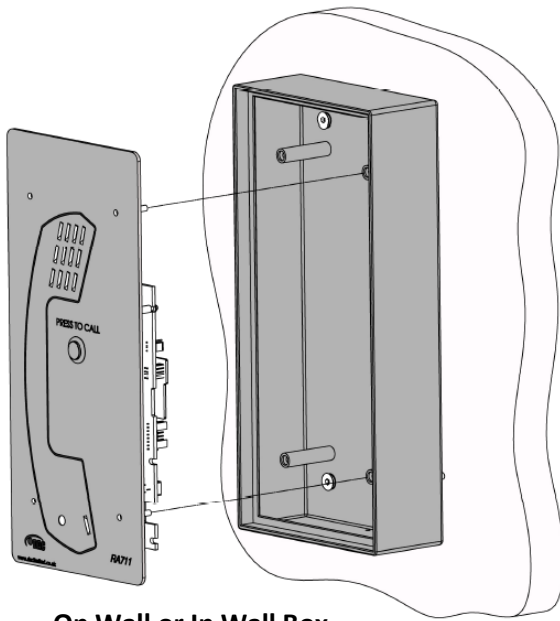

On Wall or In Wall Box

Top of Post

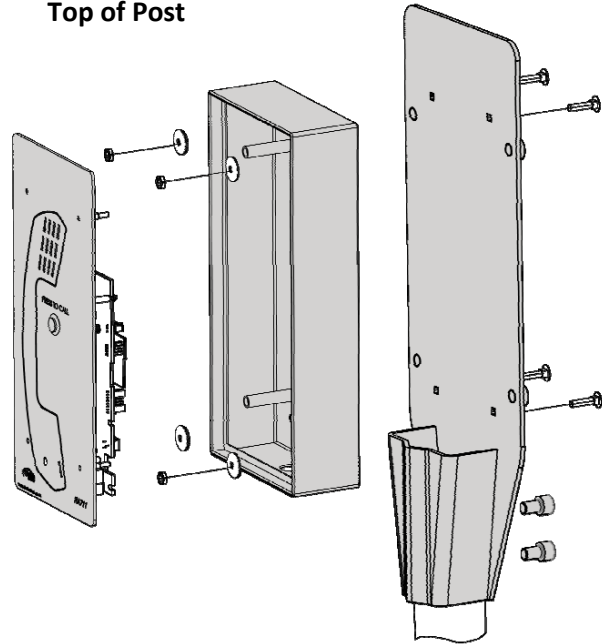

Speech/ Network Interface:

VOIP, GSM, Analogue

Ringng:

Through internal speaker, REN 1,

Power Supply:

Line powered [PSTN], POE [VoIP], DC [VoIP, GSM] battery pack [GSM], solar & wind power [GSM].

Call Cleardown/Time out:

Adjustable timer from 1 to 10 minutes or off.

Auto cleardown function [PSTN]

Temperature:

Operating: -30° C to +60° C

Storing: -40° C to +70° C

Relative Humidity:

Up to 95% (non-condensing)

Keypad/Buttons:

Heavy duty metal keypad and buttons, vandal resistant.

Material:

Robust high grade Stainless Steel

Programming:

Using on board keypad and externally connected security keypad[PSTN], web interface [VoIP], SMS [GSM]

Weight:

1.8kg

Safety:

Manufactured to BS EN 60950

Protection:

Dust and liquids IP 55

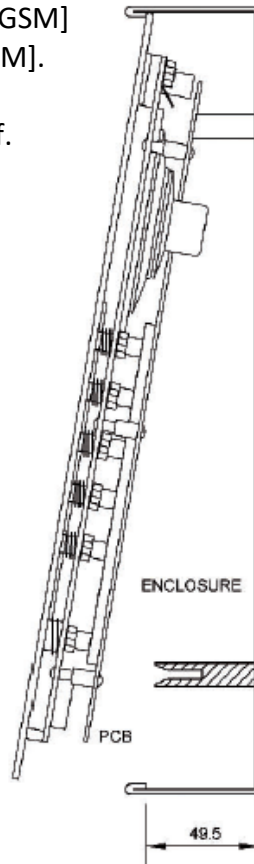

NOTE: ALL DIMENSIONS IN mm

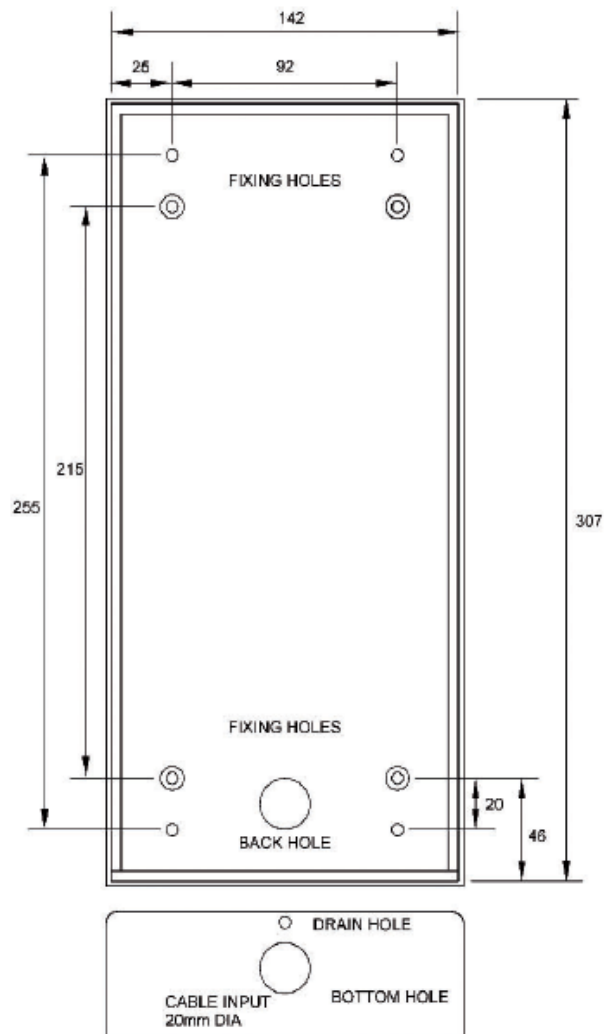

Full technical measurements available on request

